



GREAT PLAINS INDUSTRIES, INC.

"A Great Plains Ventures Subsidiary"

www.gpi.net

1-800-835-0113

CM-3120 (115-volt, NPT, Gallon or Litre)

CM-3220 (230-volt, NPT, Gallon)

CM-3260 (230-volt, BSPT, Litre)

Heavy Duty Cabinet Model Fuel Transfer System

Owner's Manual

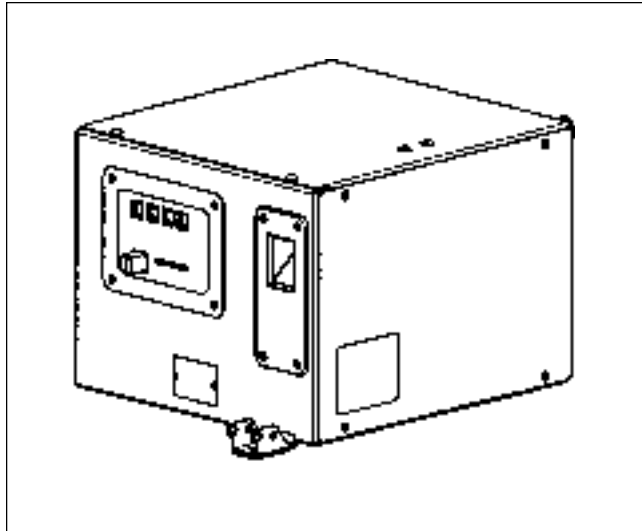

TABLE OF CONTENTS

Safety Information	1
Installation	2
Operation	4
Maintenance	5
Meter Specifications	6
Meter Troubleshooting	6
Meter Illustrated Parts Drawing	7
Pump Troubleshooting	8
Pump Illustrated Parts Drawing	9
Cabinet Illustrated Parts Drawing	10
Specifications	11
Service	11



SAFETY INFORMATION

The purpose of this manual is to assist you in installing, operating and maintaining your GPI fuel transfer system. If you need additional assistance, contact your GPI dealer or the GPI Customer Service Department.



The following safety alert symbols are used in this manual. Obey all safety messages that follow this symbol to avoid possible injury or death.

DANGER

DANGER indicates an imminently hazardous situation which, if not avoided, will result in death or serious injury.

WARNING

WARNING indicates a potentially hazardous situation which, if not avoided, could result in death or serious injury.

CAUTION

CAUTION indicates a potentially hazardous situation which, if not avoided, may result in minor or moderate injury.

CAUTION

CAUTION used without the safety alert symbol indicates a potentially hazardous situation which, if not avoided, may result in property damage.

There are inherent dangers wherever flammable fuel and AC electrical sources are in close proximity.

Static electricity as a source of sparking is always a concern and requires extreme care in the installation and operation of your entire fuel transfer system.

Additional components such as automatic nozzles and filters must be listed for use with fuel transfer systems. The flow of fuel through a hose and nozzle can generate static electrical charges and dangerous sparking can result in fire or explosion. Hoses and nozzles must be electrically conductive and bonded to ground.

It is your responsibility to:

- Know and follow applicable national, state and local safety codes pertaining to installing and operating electrical equipment for use with flammable liquids.
- Know and follow all safety precautions when handling petroleum fuels.
- Ensure that all equipment operators have access to adequate instructions concerning safe operating and maintenance procedures.

INSTALLATION

Mechanical Connections

⚠ WARNING

Coverplates protect the operator from moving parts. Never operate the fuel transfer system without coverplates in place. Never apply electric power to the fuel transfer system without coverplates in place. Always disconnect power before repairing or servicing.

Your fuel transfer system is designed for use **only** with thin viscosity petroleum fuels. **Do not** use this fuel transfer system for dispensing any fluids other than those for which it was designed.

- **CM-3120 and CM-3220:** Designed for all thin viscosity petroleum fuels such as gasoline (up to 15% alcohol blends such as E15), diesel fuel (up to 20% biodiesel blends such as B20) and kerosene.
- **CM-3260:** Designed for diesel fuel only.

Using the system with other fuels can damage components and void the warranty.

Seal all threaded fuel connections with thread tape or a pipe thread sealing compound approved for use with petroleum fuels.

Install your system according to NFPA 30A guidelines for non-commercial application on fixed above ground tanks with a maximum capacity not to exceed 6,000 gallons (22,700 litres). The tank must not be accessible to the public. The cabinet model fuel system can also be mounted on underground tanks.

For above ground tank installation, a UL Listed emergency shut-off valve with a fusible link must be installed at the pump inlet. (Figure 1)

FIGURE 1

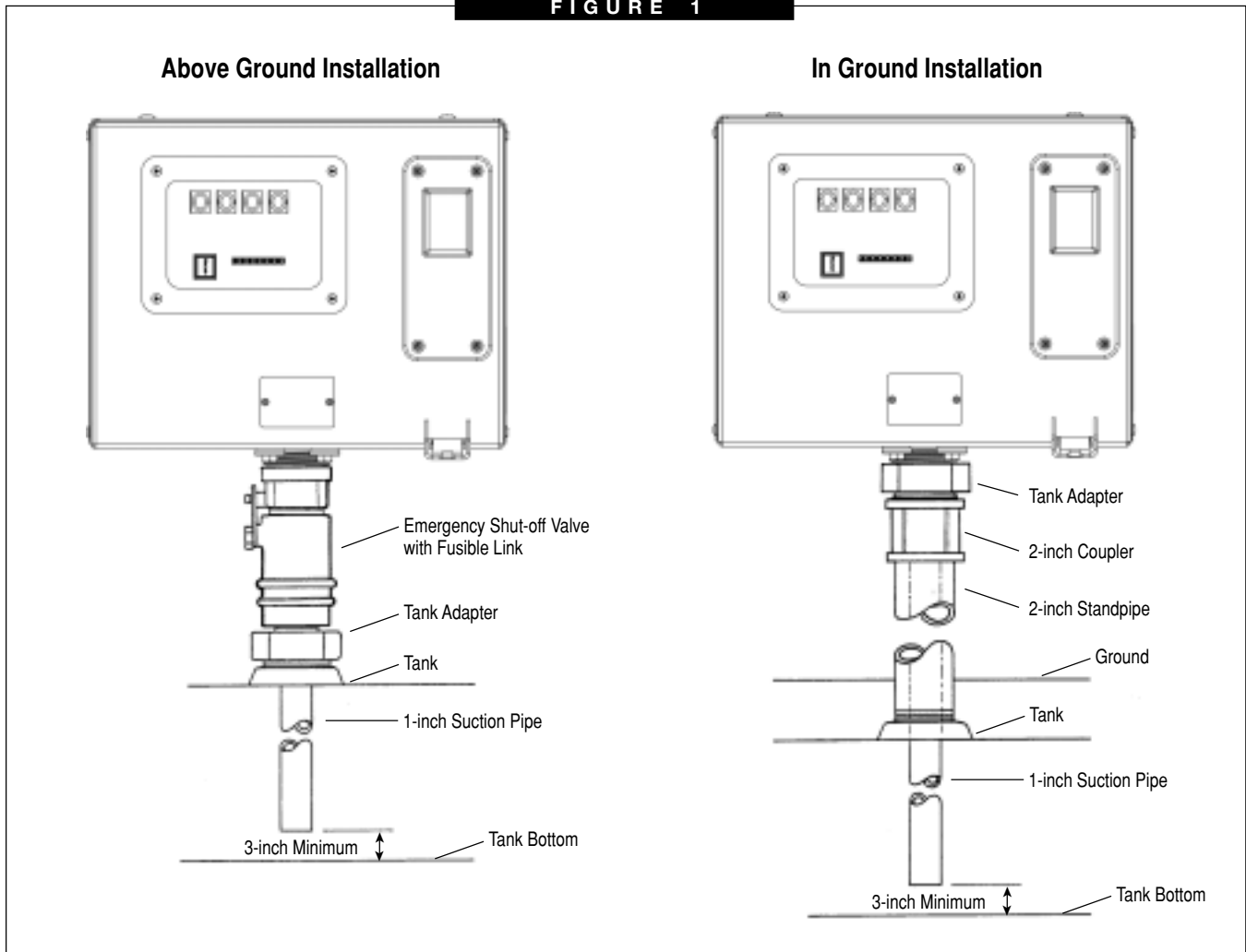

A UL Listed pressure vacuum vent must be used on your tank. If the tank is not vented, contact your GPI distributor for the correct vent cap.

The fuel transfer system pump has a built-in check valve to keep the pump primed. No additional check valve is required on suction pipes shorter than 15 feet (4.6 meters). Make sure any check valves or foot valves used are equipped with proper pressure relief valves.

Your fuel transfer system is designed to mount directly to a standard 2-inch female tank fitting. A 2-inch tank adapter fitting is included for ease of installation. For the suction pipe, a 1-inch galvanized steel pipe cut to length and threaded on one end may be used. Connect the threaded end of the suction pipe to the tank adapter, tighten securely, and install into tank. The suction pipe end should not be installed closer than 3 inches (7.6 centimeters) to the tank bottom.

Connect the pump inlet port at the bottom of the cabinet to the tank adapter and tighten securely. To avoid causing cabinet misalignment with meter, **do not** tighten by using the cabinet as a handhold. Remove a side panel cover and use an appropriate tool to grasp the pump base for tightening.

Nozzles and Hoses

All accessories for **CM-3120** and **CM-3220** must be UL Listed. Approved accessories include:

- **3/4-inch NPT, Manual Leaded Nozzle.**
(GPI Part No. 906001-6)
- **3/4-inch NPT, Automatic Leaded Nozzle.**
(GPI Part No. 906004-98)
The hanger bracket attached to the nozzle tube must be removed before using this nozzle with the system.
- **Hose Assembly, 3/4-inch NPT x 12 ft. (3.7m)**
(GPI Part No. 110049-2)
Or any UL Listed hose assembly.

NOTE: Use of other off-the-shelf nozzles may result in malfunction and reduced system performance.

The nozzle hanger can be positioned for either a manual or automatic nozzle. The cabinet is shipped with the nozzle hanger positioned for a manual nozzle.

If an automatic nozzle will be used:

1. Remove the side cover panel, switch pin, adjacent washers and switch rod. (Figure 2)

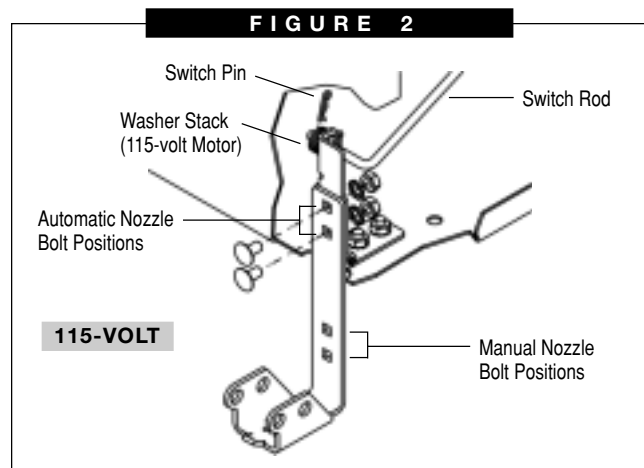

2. Remove the two (2) hanger retaining nuts and bolts and slide the hanger downward until the upper bolt holes in the hanger align with the hanger mounting holes in the hinge assembly. Replace nuts and bolts and tighten securely.
3. Replace switch rod, washers, switch pin and side cover panel.

When reconnecting the switch rod to the hinge assembly, the five (5) washer stack for the 115-volt system locates to the inboard side of the flange (Figure 2), and to the outboard side of the flange on a 230-volt system. (Figure 3)

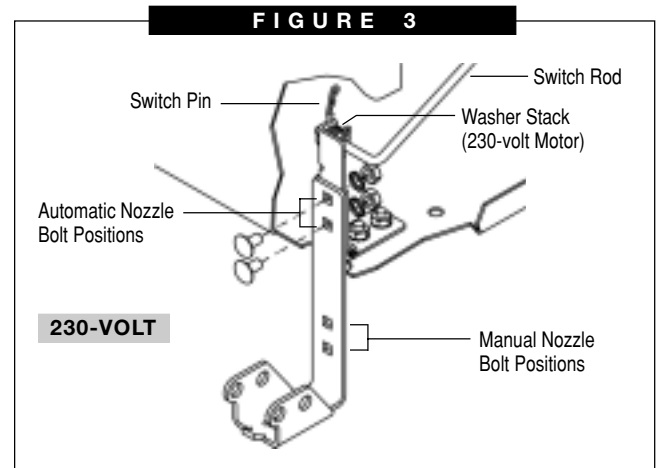

Electrical Connections

⚠ DANGER

The fuel transfer system must be installed by a licensed electrician and conform to National Fire Protection Association (NFPA) codes 30 and 70 or Canadian Electric Code C22.1 as applicable. You, as the owner, are responsible for seeing that the installation and operation of your system complies with NFPA codes as well as any applicable state and local codes. Rigid conduit must be used to install wiring.

Failure to follow these wiring instructions may result in death or serious injury from shock, fire or explosion.

The system must be properly grounded to avoid personal injury. Operating an ungrounded or improperly grounded system may result in death due to electrical shock, fire or explosion.

Electrical wiring and connections must be made only by a licensed electrician in accordance with national, state and local electrical codes regarding Class I, Division 1, Group D locations. Other codes may apply.

The thread for the conduit connection at the pump electrical box is 1/2-inch FNPT.

A standard 15-amp breaker is recommended.

This pump is equipped with an auxiliary AC accessory lead. The third wire (brown for 115-volt system and purple for 230-volt system) is to be used to energize a control circuit that operates a device such as a signal light or a solenoid operated valve. Maximum amp draw on the control circuit is 1 amp. If you do not need this feature, ensure that the wire is insulated and enclosed within the electrical cavity of the pump.

Outside the United States, installation should be performed in compliance with local codes.

CAUTION

Connect pump to the proper voltage source.

- **CM-3120 Fuel Transfer System** is designed to operate on 115 VAC, 60 Hz.
- **CM-3220 and CM-3260 Fuel Transfer Systems** are designed to operate on 220-240 VAC, 50/60 Hz.

Connection to improper voltage will damage pump.

Wiring Details

1. Remove electrical coverplate. (Figure 4) Install conduit and cable from switchbox to pump electrical box. Wiring must be in accordance with Class I, Division 1 requirements in the applicable national electrical code.

FIGURE 4

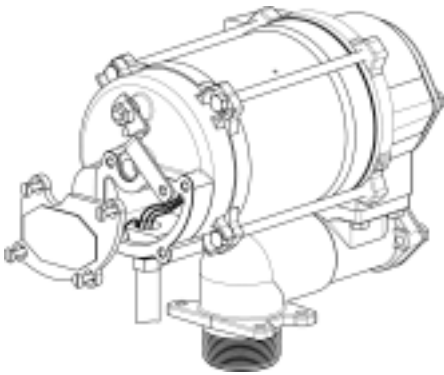

2. Attach ground wire using the green ground screw located inside the electrical box. (Figure 5) For 115-volt system connect the power cable to the black and white pump wires and the control circuit (if required) to the brown wire. For 230-volt system connect the power cable to the brown and blue pump wires and the control circuit (if required) to the purple wire. Secure with wire nuts.

FIGURE 5

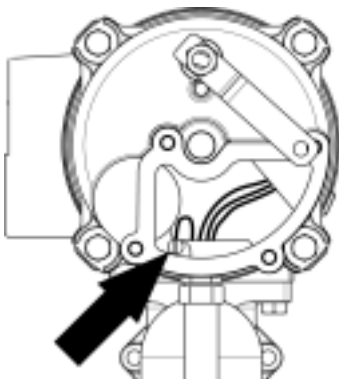

3. Position wires inside the electrical box. Replace electrical coverplate with all four (4) screws and tighten securely.

OPERATION

DANGER

To prevent physical injury, observe precautions against fire or explosion when dispensing fuel. Do not operate the system in the presence of any source of ignition including running or hot engines, lighted cigarettes, or gas or electric heaters.

WARNING

Observe precautions against electrical shock when operating the system. Serious or fatal shock can result from operating electrical equipment in damp or wet locations.

CAUTION

Avoid prolonged skin contact with petroleum fuels. Use protective goggles, gloves, and aprons in case of splashing or spills. Change saturated clothing and wash skin promptly with soap and water.

Fuel Meter Display

The Batch Total for each fuel delivery is displayed on the front of the cabinet. Before dispensing, reset the Batch Total to zero by pushing the reset button. (Figure 6)

FIGURE 6

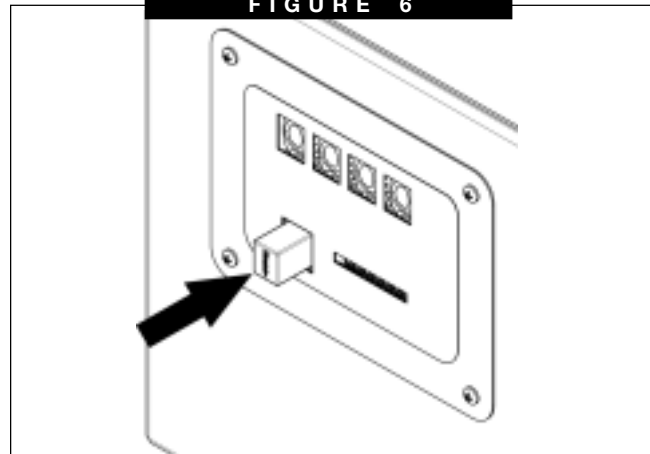

The small display represents the Cumulative Total of all fuel deliveries and cannot be reset.

To Dispense Fuel

1. Remove the nozzle from the nozzle hanger. Turn the pump on by lifting upward on the nozzle hanger.

NOTE: If an automatic nozzle is installed, lift upward and outward on the nozzle hanger due to increased length of hanger.

2. Insert the nozzle into the receiving tank and squeeze the handle to dispense fuel.

- After dispensing fuel, push the nozzle hanger down to turn the pump off and return nozzle to the holder. The pump motor cannot be operated with nozzle in the holder. Use the lock holes provided to lock the nozzle in place to prevent unauthorized use. (Figure 7)

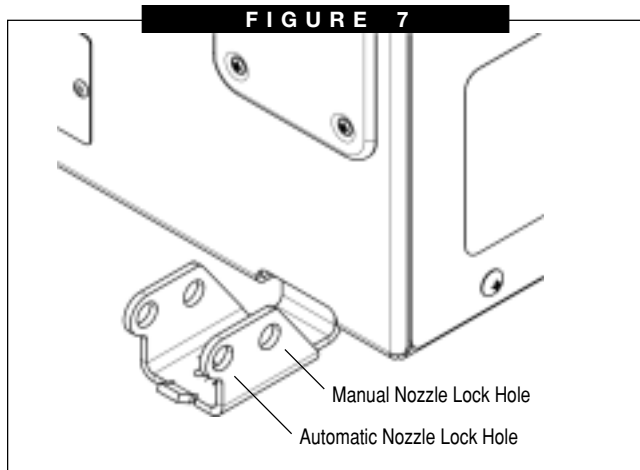

The pump contains an automatic bypass valve to prevent pressure buildup when the pump is on but the nozzle is closed. Do not leave the pump on for more than 10 minutes with the nozzle closed.

Never leave the pump running without fluid. Dry running can damage the pump components.

The pump has a duty cycle of 30 minutes ON and 30 minutes OFF. Do not overheat. Allow the motor to cool the same length of time it was in operation.

The fuel strainer and check valve assembly should be cleaned on a regular basis or if low flow rate is noticed.

If the pump becomes too hot, a thermal protector will automatically shut the motor off and prevent operation until it cools.

CAUTION

Always turn the pump off if the thermal protector trips. If left on, the pump will automatically reset when cool and start pumping.

MAINTENANCE

WARNING

Coverplates protect the operator from moving parts. Never operate the fuel transfer system without coverplates in place. Never apply electric power to the fuel transfer system without coverplates in place. Always disconnect power before repairing or servicing.

Meter Calibration

The meter is accurately calibrated at the factory for use with diesel fuel. Due to differences in viscosity and flow rates, the meter may require recalibration to measure other fuels or to adjust for inaccuracies.

To Calibrate the Meter:

- Purge air from the meter and fuel system by dispensing fuel into a container until a full flow occurs. Close the nozzle.
- Reset the meter counter to zero by pressing the reset button. (Figure 6)
- Pump into a graduated calibration container to a specified quantity. For the greatest accuracy, be sure the container is placed on a level surface and a consistent flow rate is used. When topping off the calibration container, use a quick-open and quick-close method until the mark is reached.

NOTE: Your GPI dealer can supply a calibration container designed for this purpose. (Figure 8)

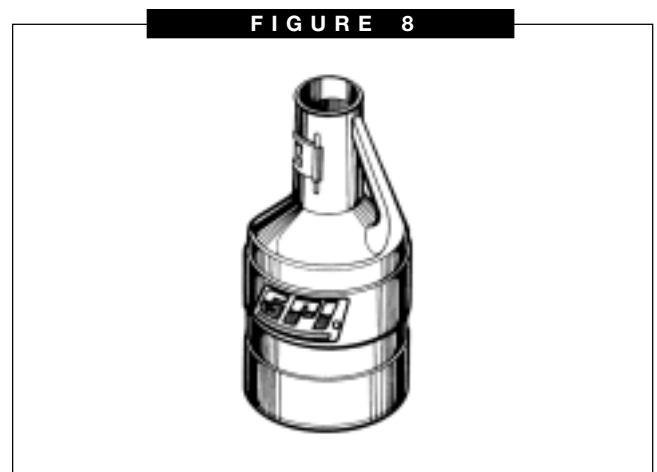

- Compare the meter display to the quantity in the container. If the display does not register the quantity in the container, adjust the meter as follows:

Adjusting the Meter:

- Remove the cabinet side cover panel adjacent to meter register. Gain access to the recessed calibration screw by turning the calibration screw cover and seal counter-clockwise. Remove the cover and nylon washer. (Figure 9)

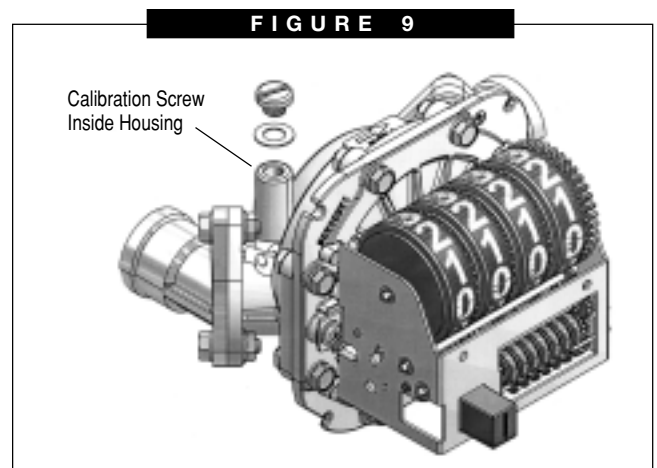

METER SPECIFICATIONS

- If the meter registered less than the quantity in the container, turn the calibration screw **clockwise**. If the meter display read **more** than the amount in the container, turn the calibration screw **counterclockwise**.
- Empty the calibration container and repeat steps 2 to 4 of the Meter Calibration instructions until the meter registers the quantity in the container.
- Install the nylon washer, calibration screw cover and replace cabinet side cover panel.

Clean or Replace Strainer

To gain access to the meter, remove both cabinet side cover panels, remove nuts and screws attaching two U-bolt brackets to cover and remove top cabinet cover.

- Remove the nuts and bolts at the inlet fitting of the meter. Remove the O-ring and strainer.
- Using a fine brush, clean the strainer. Replace the strainer as necessary.
- Wipe clean the inlet, housing and O-ring groove. Coat the O-ring with oil or light grease. Make sure the O-ring is fully seated. Replace the strainer.
- Position the inlet fitting in the original orientation and tighten the nuts and bolts until snug.
- Replace top cabinet cover, replace and tighten U-bolt brackets, nuts and screws and replace both side cover panels.

Unit of Measure:

U.S. gallons or litres

Flow Range:

5 to 30 GPM (19 to 114 LPM)

Typical Accuracy:

± 2%

Type:

Nutating Disc

Housing Material:

Aluminum

Maximum Working Pressure:

50 PSIG (3.4 bar)

Inlet/Outlet Fitting Size:

3/4-inch NPT

Maximum Batch Total:

999.9 (9999 for litre)

Maximum Cumulative Total:

999,999.9 (9,999,999 for litre)

METER TROUBLESHOOTING

SYMPTOM	PROBABLE CAUSE	CORRECTIVE ACTION
A. METER COUNTER DOES NOT OPERATE (Normal fuel delivery)	<ol style="list-style-type: none"> Broken counter assembly Foreign material in counter assembly or nutator assembly Broken nutator disc pin or defective nutator assembly Jammed material in nutator assembly 	<p>Replace counter.</p> <p>Remove and clean counter assembly or nutator assembly.</p> <p>Install new nutator assembly.</p> <p>Contact GPI Customer Service.</p>
B. METER COUNTER DOES NOT OPERATE (Little or no fuel flow)	<ol style="list-style-type: none"> Clogged strainer in meter Other system components malfunctioning Foreign material in nutator assembly 	<p>Clean or replace strainer.</p> <p>Check all system components from tank to nozzle for clogs and/or malfunctions. Repair as necessary.</p> <p>Remove and clean nutator assembly.</p>
C. FUEL LEAKAGE	<ol style="list-style-type: none"> Leakage at counter drive shaft Leakage between coverplate and housing Leakage at fittings Leakage at threads 	<p>Replace coverplate assembly.</p> <p>Remove coverplate and inspect for damaged, missing or incorrectly seated seal. Replace as required.</p> <p>Remove fittings and inspect for damaged, missing or incorrectly seated seals. Replace as required.</p> <p>Remove meter and reseal all threaded connections with Teflon® tape or pipe thread sealing compound approved for use with flammable liquids.</p>

METER ILLUSTRATED PARTS DRAWING

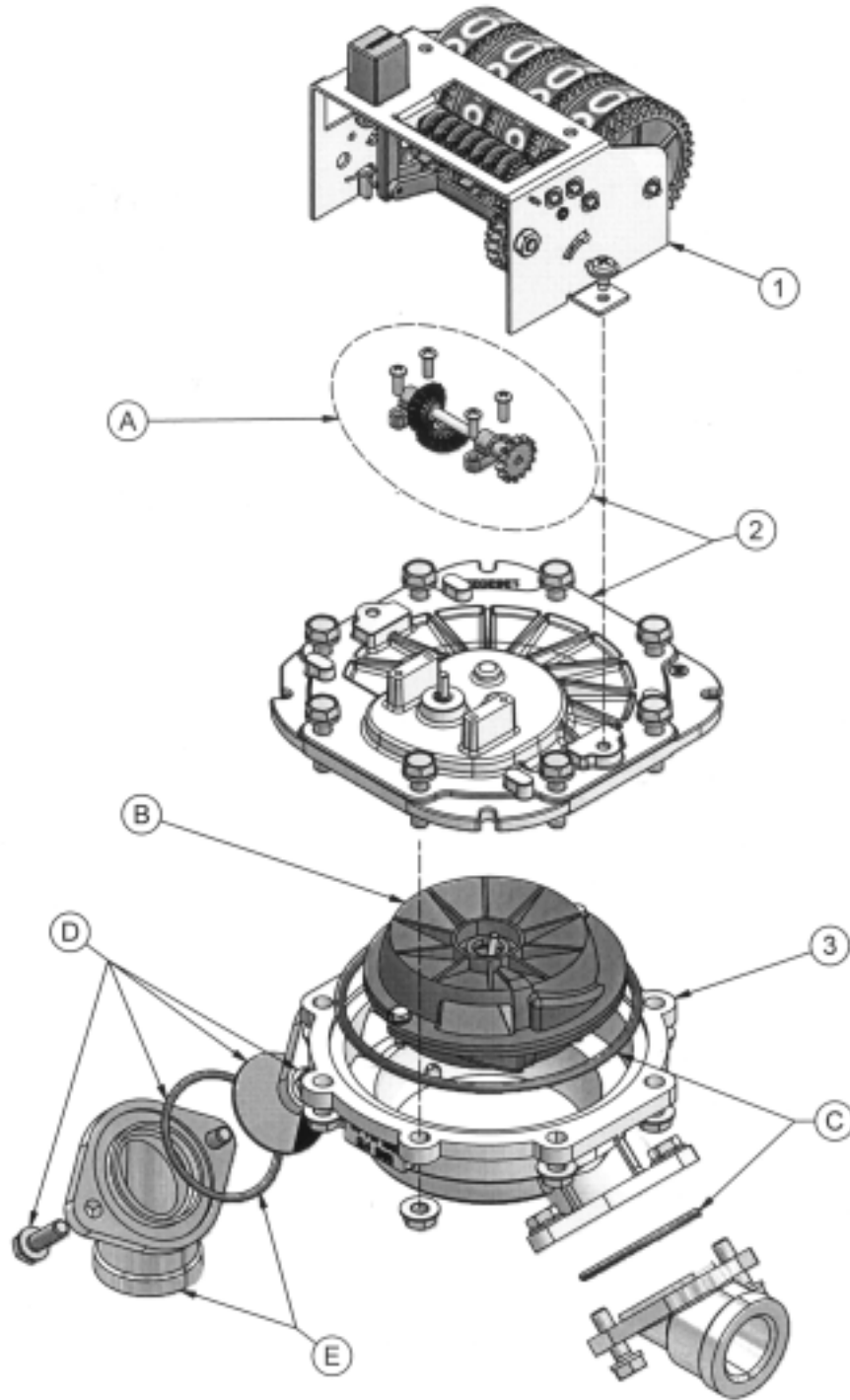

Item No.	Part No.	Description	No. Req'd.
1	126514-05	Counter Assembly, Gallons	1
	126514-06	Counter Assembly, Litres	1
2	126514-07	Coverplate Assembly, Gallons	1
	126514-08	Coverplate Assembly, Litres	1
3	126010-1	Housing	1
	111014-3	Calibration Screw (not shown)	1
	111026-1	Seal, Calibration Screw (not shown)	1
	111039-2	Cover, Calibration Screw (not shown)	1
	904006-16	Washer, Calibration Screw Cover (not shown)	1

Kits and Accessories

- A** 126514-03 Gear Assembly Kit, Gallons
- 126514-04 Gear Assembly Kit, Litres
- B** 126503-1 Nutator Assembly Kit
- C** 126509-1 Seal Kit (Housing O-Ring, Fitting O-Rings)
- D** 126512-1 Hardware Kit (Fitting O-Rings, Strainer, Screws, Nuts)
- E** 126501-1 Fitting Kit for 3/4-inch NPT (2 Fittings, 2 Fitting O-Rings)

PUMP TROUBLESHOOTING

SYMPTOM	PROBABLE CAUSE	CORRECTIVE ACTION
A. MOTOR DOES NOT RUN	<ol style="list-style-type: none"> 1. No electrical power to pump 2. Thermal protector tripped 3. Rotor or vanes jammed 	<p>Check breaker, switchbox and wiring.</p> <p>Allow motor to cool. Thermal protector will automatically reset.</p> <p>Remove coverplate and check for damage or obstruction.</p>
B. MOTOR RUNS, BUT NO FLOW	<ol style="list-style-type: none"> 1. Tank level low 2. Clogged filter assembly 3. Clogged or broken suction pipe 4. Broken shaft key 	<p>Add fuel to tank.</p> <p>Remove and clean filter assembly.</p> <p>Remove pump and clear suction pipe. Replace as needed.</p> <p>Replace shaft key. Check rotor or vanes for obstruction.</p>
C. PUMP FAILS TO PRIME	<ol style="list-style-type: none"> 1. Air leak in system 2. Bypass valve stuck open 3. Check valve stuck open 4. Rotor or vanes worn 	<p>Check for air leaks at all joints.</p> <p>Remove bypass valve and clean or replace as needed.</p> <p>Remove check valve and clean or replace as needed.</p> <p>Check rotor and vanes for excessive wear.</p>
D. LOW FLOWRATE	<ol style="list-style-type: none"> 1. Low voltage 2. Clogged filter assembly 3. Air leak in system 4. Bypass valve stuck open 5. Rotor or vanes worn 6. Outlet is blocked 7. Clogged or broken suction pipe 	<p>Check incoming line voltage.</p> <p>Clean filter assembly.</p> <p>Check for air leaks at all joints.</p> <p>Remove bypass valve and clean or replace as needed.</p> <p>Check rotor and vanes for excessive wear.</p> <p>Check all accessories for blockage.</p> <p>Remove pump and clear suction pipe. Replace as needed.</p>
E. MOTOR STALLS WHEN NOZZLE IS CLOSED	<ol style="list-style-type: none"> 1. Bypass valve stuck closed 2. Rotor or vanes worn 3. Low voltage 	<p>Remove bypass valve and clean or replace as needed.</p> <p>Check rotor and vanes for excessive wear.</p> <p>Check incoming line voltage.</p>
F. FUEL LEAKAGE	<ol style="list-style-type: none"> 1. Threaded joint loose 2. Insufficient bolt torque 3. Lost or damaged O-rings 4. Shaft seal worn or damaged 	<p>Check and reseal threaded joint.</p> <p>Retighten bolts.</p> <p>Check O-rings for damage. Replace as needed.</p> <p>Fuel leaking from drain hole indicates shaft seal needs to be replaced.</p>
G. MOTOR OVERHEATS	<ol style="list-style-type: none"> 1. Pumping high viscosity fluids 2. Clogged filter assembly 3. Clogged or broken suction pipe 	<p>Pump only low viscosity fluids.</p> <p>Clean filter assembly.</p> <p>Remove pump and clear suction pipe. Replace as needed.</p>

PUMP ILLUSTRATED PARTS DRAWING

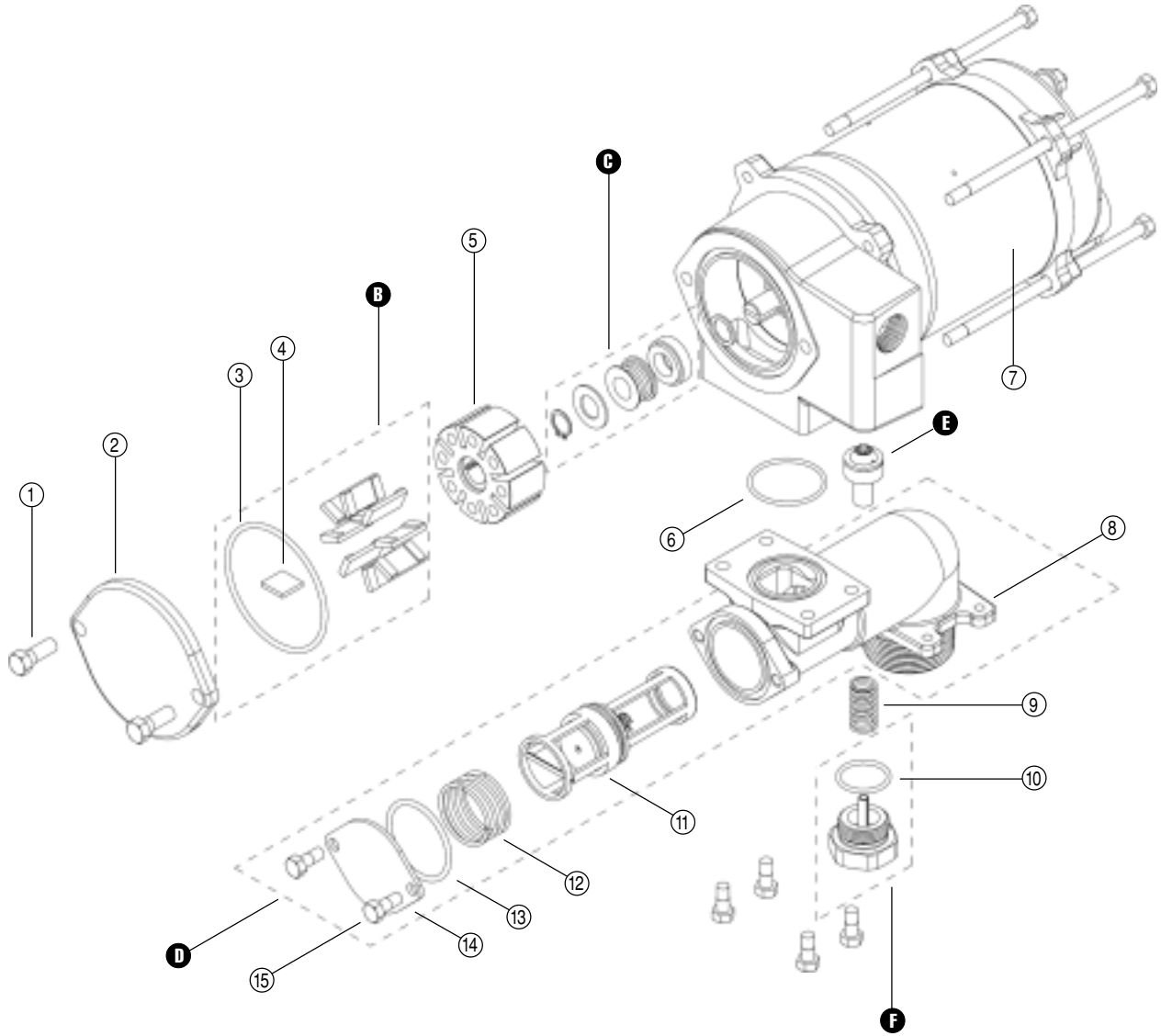

Item No.	Part No.	Description	No. Req'd.
1	904006-38	Hex Head Screw, 3/8-16 x 1 in.	2
2	133032-1	Coverplate	1
3	901003-15	O-Ring or (Kit A)	1
4	121010-1	Shaft Key	1
5	133022-1	Rotor	1
6	901002-89	O-Ring or (Kit A)	1
7	133506-01	1/3 HP Motor Assy, 115-volt (CM-3120)	1
	133507-02	1/3 HP Motor Assy, 230-volt (CM-3220/CM-3260) ...	1
8	133439-01	Base Machined, NPT (CM-3120/CM-3220)	1
	133439-02	Base Machined, BSPT (CM-3260)	1
9	133062-1	Poppet Spring	1
10	901002-50	O-Ring or (Kit A)	1
11	121013-1	Check Valve Assembly	1
12	121019-1	Spring	1
13	901001-90	O-Ring or (Kit A)	1
14	133033-1	Base End Plate	1
15	904001-37	Hex Head Screw, 5/16-18 x 3/4 in.	6

Kits and Accessories

- A** 133504-1 Seal Kit (not shown)
- B** 133501-1 Vane Kit
- C** 133503-1 Shaft Seal Kit
- D** 133052-05 Base Assy, NPT with Check Valve (CM-3120/CM-3220)
- 133052-06 Base Assy, BSPT with Check Valve (CM-3260)
- E** 133505-01 Poppet Assembly Kit
- F** 133505-02 Poppet Plug Assembly Kit

CABINET ILLUSTRATED PARTS DRAWING

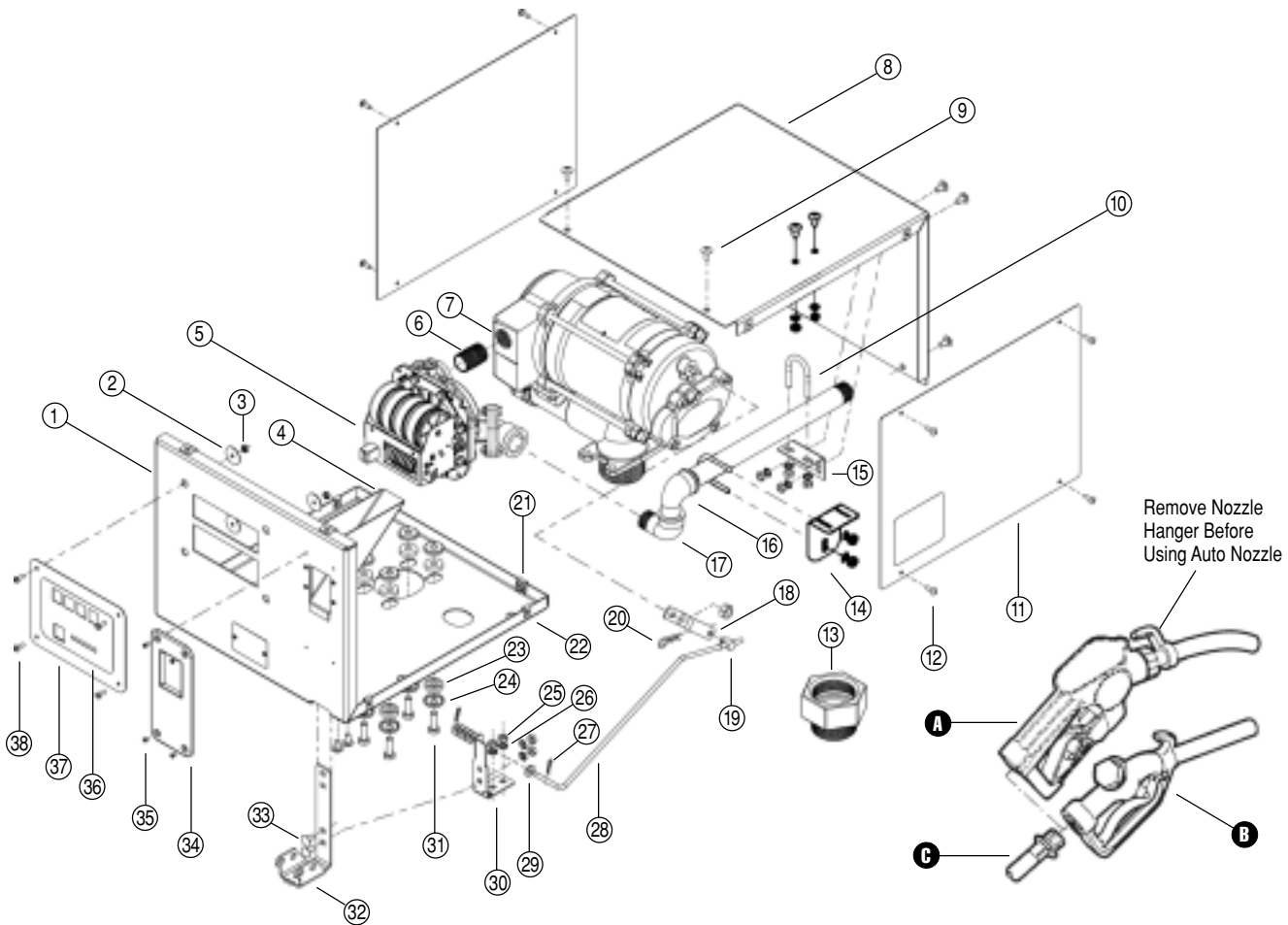

Item No.	Part No.	Description	No. Req'd.
1	133411-01	Cabinet Panel, Front/Bottom	1
2	904006-96	Washer, Flat Fender, #8	4
3	904006-98	Nut, K-Lock, External Tooth, #8-32	4
4	133422-01	Nozzle Chute	1
5	12620105	Meter Assembly*, Gallon (CM-3120/CM-3220)	1
	12620106	Meter Assembly*, Litre (CM-3120/CM-3260)	1
6	904005-9	Pipe Nipple, 3/4-inch NPT x 1-1/2 in. Length	1
7	133402-01	Pump Assembly*, 115-volt, NPT (CM-3120)	1
	133402-02	Pump Assembly*, 230-volt, NPT (CM-3220)	1
	133402-03	Pump Assembly*, 230-volt, BSPT (CM-3260)	1
8	133412-01	Cabinet Panel, Top/Back	1
9	904006-99	Screw, Truss Head Machine, 1/4-20 x 1/2 in.	10
10	904004-75	U-Bolt, with 1/4-20 Nuts	2
11	133414-01	Cabinet Panel, Side	2
12	904001-72	Screw, Truss Head Tapping, #8 x 1/2	8
13	121231-1	Tank Adapter, 2 in. x 1-inch NPT (CM-3120/CM-3220)	1
	121231-2	Tank Adapter, 2 in. x 1-inch BSPP (CM-3260)	1
14	133415-01	Bracket, Upper, Outlet	1
15	133417-01	Bracket, Pipe	1
16	904007-01	Pipe Nipple, 3/4-inch NPT x 12 in. Length (CM-3120/CM-3220)	1
	133460-01	Pipe Nipple, 3/4-inch NPT x 3/4-inch BSPT (CM-3260)	1

Item No.	Part No.	Description	No. Req'd.
17	904004-73	Fitting, Elbow (90° Street), 3/4-inch NPT	2
18	133418-01	Switch Lever	1
19	121237-1	Linkage, Switch	1
20	904002-58	Pin, Hitch Clip, .093	1
21	904007-02	Fastener, U-Type, 1/4-20 Nut	4
22	904001-10	Fastener, U-Type	8
23	901002-53	Bushing, Step	8
24	904004-38	Washer, Centering	8
25	904001-25	Nut, Hex, 1/4-20	8
26	904001-22	Washer, Lock, 1/4 in., External Tooth	12
27	904004-82	Pin, Hitch Clip, .056	2
28	133420-01	Switch Rod	1
29	904001-21	Washer, Flat, 1/4 in., Plain Narrow	6
30	121235-1	Hinge Assembly	1
31	904004-37	Screw, Hex Head, 5/16-18 x 1 in.	4
32	133451-01	Hanger, Nozzle	1
33	904004-80	Bolt, Round Head Short Sq. Neck, 1/4-20 x 1/2 in.	2
34	121217-1	Plate	1
35	904002-81	Screw, Oval Head Tapping, #6 x 1/4	4
36	12620239	Decal (Gallon)	1
	12620240	Decal (Litre)	1
37	133443-01	Coverplate, Meter	1
38	904006-97	Screw, Pan Head Machine, #8-32 x 1/2 in.	4

* Reference the Meter Illustrated Parts Drawing
 † Reference the Pump Illustrated Parts Drawing

Kits and Accessories

- A** 906004-98 3/4-inch NPT Automatic Leaded Nozzle (Remove Hanger Bracket on Nozzle)
- B** 906001-6 3/4-inch NPT Manual Leaded Nozzle
- C** 110049-2 Hose Assembly, 3/4-inch NPT x 12 ft., Buna-N Statically Grounded

SPECIFICATIONS

The CM-3120 and CM-3220 Fuel Transfer Systems are designed to safely transfer low viscosity petroleum fuels such as gasoline (up to 15% alcohol blends such as E15), diesel fuel (up to 20% biodiesel blends such as B20) and kerosene. The CM-3260 Fuel Transfer System is designed to safely transfer diesel fuel. All models are designed for permanent mounting on vented storage tanks, either in-ground or above-ground.

Performance

Pump Rate: CM-3120: Up to 20 GPM (76 LPM)
CM-3220: Up to 20 GPM @ 60 Hz,
Up to 17 GPM @ 50 Hz
CM-3260: Up to 64 LPM @ 50 Hz

Duty Cycle: 30 minutes ON, 30 minutes OFF

Dry Prime: 15 ft. (4.6m) maximum

Discharge Lift: 10 ft. (3m) maximum

Electrical

Input: CM-3120: 115-volt AC, 60 Hz
CM-3220: 220-240-volt AC, 50-60 Hz
CM-3260: 220-240-volt AC, 50-60 Hz

Conduit: 1/2-inch FNPT

Current Draw: CM-3120: 4.9 amps at full load
CM-3220: 2.3-2.5 amps at full load
CM-3260: 2.3-2.5 amps at full load

Motor: CM-3120: 1/3 HP, 1725 RPM
CM-3220: 1/3 HP, 1725 RPM @ 60 Hz,
.19 kW, 1425 RPM @ 50 Hz
CM-3260: .19 kW, 1425 RPM
All are induction type with internal temperature-limiting device.

Mechanical Connections

Bung: CM-3120: 2-inch MNPT
CM-3220: 2-inch MNPT
CM-3260: 2-inch MBSPT

Inlet: CM-3120: 1-inch FNPT
CM-3220: 1-inch FNPT
CM-3260: 1-inch FBSPP

Outlet: CM-3120: 3/4-inch NPT
CM-3220: 3/4-inch NPT
CM-3260: 3/4-inch BSPT



Accessories Available

Hose: 3/4 in. x 12 ft. (3.7m) Buna-N electrically conductive

Nozzle: 3/4 in. manual or 3/4 in. automatic, leaded spout

Security Nozzle can be padlocked

Ship Weight 77 pounds (34.9 kg)

Certifications CM-3120 and CM-3220: 
CM-3260: 

SERVICE

In order to preserve the UL Listing for pump safety, return the entire pump to the factory for repair or replacement. For products serviced outside the factory, the UL nameplates must be defaced to indicate that the equipment may no longer meet the requirements for UL Listing. This does not apply to products serviced outside the factory under the UL program for Rebuilt Motors for Use in Hazardous Locations.

For warranty consideration, parts, or other service information, please contact your local distributor. If you need further assistance, contact the GPI Customer Service Department in Wichita, Kansas, during normal business hours. A toll free number is provided for your convenience.

1-800-835-0113

To obtain prompt, efficient service, always be prepared with the following information:

1. The model number of your Fuel Transfer System.
2. The manufacturing date code of your Fuel Transfer System.

The manufacturing date code is located on the model nameplate riveted to the front of the cabinet.

For warranty work, always be prepared with your original sales slip or other evidence of purchase date.

Please contact GPI before returning any Fuel Transfer System. It may be possible to diagnose the trouble and find a solution with a telephone call. GPI can also inform you of any special requirements you will need to follow for shipping.

CAUTION

Do not return the pump without authority from the Customer Service Department. Due to strict government regulations, GPI cannot accept pumps unless they have been drained and cleaned.

SAVE THESE INSTRUCTIONS

Limited Warranty Policy

Great Plains Industries, Inc. 5252 E. 36th Street North, Wichita, KS USA 67220-3205, hereby provides a limited warranty against defects in material and workmanship on all products manufactured by Great Plains Industries, Inc. This product includes a 2 year warranty. Manufacturer's sole obligation under the foregoing warranties will be limited to either, at Manufacturer's option, replacing or repairing defective Goods (subject to limitations hereinafter provided) or refunding the purchase price for such Goods theretofore paid by the Buyer, and Buyer's exclusive remedy for breach of any such warranties will be enforcement of such obligations of Manufacturer. The warranty shall extend to the purchaser of this product and to any person to whom such product is transferred during the warranty period.

The warranty period shall begin on the date of manufacture or on the date of purchase with an original sales receipt. This warranty shall not apply if:

- A. the product has been altered or modified outside the warrantor's duly appointed representative;
- B. the product has been subjected to neglect, misuse, abuse or damage or has been installed or operated other than in accordance with the manufacturer's operating instructions.

To make a claim against this warranty, contact the GPI Customer Service Department at 316-686-7361 or 800-835-0113. Or by mail at:

Great Plains Industries, Inc.
5252 E. 36th St. North
Wichita, KS, USA 67220-3205

The company shall, notify the customer to either send the product, transportation prepaid, to the company at its office in Wichita, Kansas, or to a duly authorized service center. The company shall perform all obligations imposed on it by the terms of this warranty within 60 days of receipt of the defective product.

GREAT PLAINS INDUSTRIES, INC., EXCLUDES LIABILITY UNDER THIS WARRANTY FOR DIRECT, INDIRECT, INCIDENTAL AND CONSEQUENTIAL DAMAGES INCURRED IN THE USE OR LOSS OF USE OF THE PRODUCT WARRANTED HEREUNDER.

The company herewith expressly disclaims any warranty of merchantability or fitness for any particular purpose other than for which it was designed.

This warranty gives you specific rights and you may also have other rights which vary from U.S. state to U.S. state.

Note: In compliance with MAGNUSON MOSS CONSUMER WARRANTY ACT – Part 702 (governs the resale availability of the warranty terms).



5252 East 36th Street North
Wichita, KS USA 67220-3205
TEL: 316-686-7361
FAX: 316-686-6746

GREAT PLAINS INDUSTRIES, INC.

"A Great Plains Ventures Subsidiary"

www.gpi.net

1-800-835-0113