

Balcrank[®]

**Pit Boss
Rolling Pit Drain
MODEL 4140-011
MODEL 4140-020**



Thoroughly read and understand this manual before installing, operating or servicing this equipment.

**OPERATION, INSTALLATION,
MAINTENANCE AND REPAIR GUIDE**

General Safety

Thoroughly read and understand this manual before installing, operating or servicing the described products.



IMPORTANT

Check equipment regularly and repair or replace worn and damaged parts.

Never alter or modify any parts of this drain, doing so may cause damage to drain and/or personal injury.



WARNING

To reduce the risk of the pit drain falling off of the pit tracks, which could cause serious injury to someone near the pit drain, NEVER extend the wheel supports further than the maximum extension (see dimensional drawing).



WARNING

Do not step on the pit drain.

General Description

Model 4140-011 Pit Boss Rolling pit drain has a capacity of 34 gallons. It easily rolls on guide tracks in the user's pit. Features include metal catch screen, anti-splash baffles, side splash guards, ball drain valve, cam-lock half coupler, and front and rear drain ports. Three (3) inch diameter wheels are mounted to accommodate a pit track width of 36" to 50". The wheels are also adjustable 2" up or down. A handy tool shelf is provided below the tank for pit service tools.

Installation

Assemble the four wheels (8) to the four wheel supports (10) if necessary. Install the assembled wheel supports in the support guides. Extend the wheel supports equally on both sides of the drain pan to fit the pit tracks. DO NOT extend the wheel supports further than the maximum extension. Tighten the support bolts (1) securely.

Attach the pipe bushing (4), pipe nipple (16), ball valve (13), and cam-lock adapter (14) to one of the drain ports. Make sure the pipe plug (7) is installed tightly in the other drain port. Use thread sealant of choice to prevent leaks.

Operating Instructions

To evacuate oil from the pit drain, connect the evacuation hose to the cam-lock adapter and open ball valve. Be sure to close the ball valve before using the pit drain again.

Optional Accessories for Pit Boss Rolling Pit Drain

4140-012 Connector Hose: 2' x 1" connector hose with female cam-lock connectors on both ends. Used to connect two rolling pit drains for evacuation from one side.

4140-013 Evacuation Hose: 2' x 1" evacuation hose with female cam-lock connector on one end and 1" NPT male fitting on the other end. Used to attach pit drain to evacuation manifold.

4140-014 Tandem Pit Drain Kit: Consists of connector hose, ball valve, pipe nipple, bushing, cam-lock nipple, and cam-lock dust cover. Used to connect two tandem Pit Bosses in a common pit for flow through evacuation. See diagram on the next page.

Parts

ITEM	PART #	DESCRIPTION	QTY	ITEM	PART #	DESCRIPTION	QTY
1	805795	Bolt	4	9	828214	Tank Weldment	1
2	805939	Hex Nut	4	10	828218	Wheel Support	4
3	813903	Lock Washer	4	11	828228	Screen Assembly	1
4*		Not Used		12	828324	Bolt	4
5	821422	Nipple	1	13*	828370	Ball Valve	1
6*	828001	Screen	1	14*	828373	Cam-Lock Adapter	1
7*	820207	Pipe Plug	1	15*	828374	Dust Cover	1
8	828212	Wheel	4	16*	3270-045	Nipple	1

Dimensional Drawing

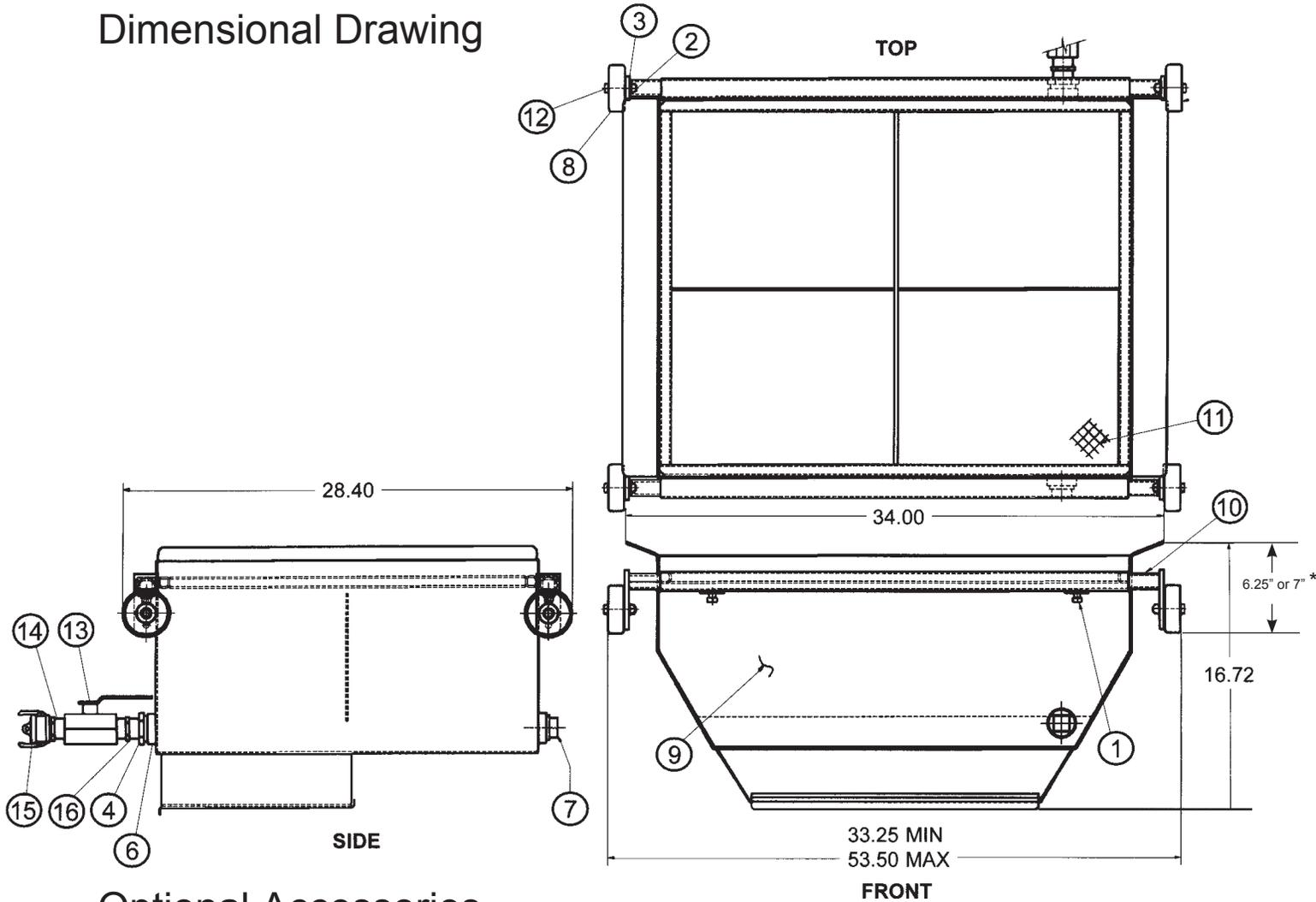

Optional Accessories Diagram

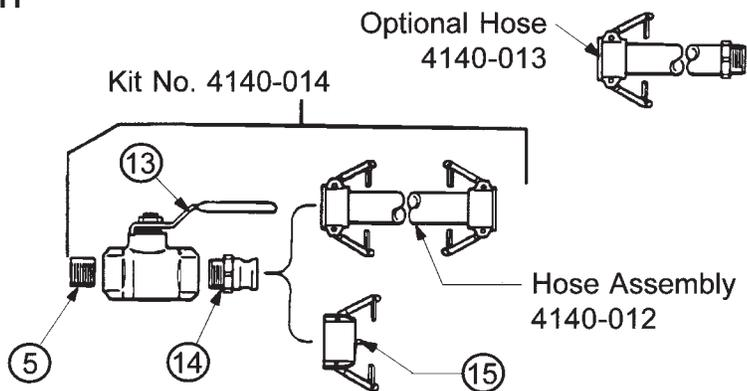

* Dependant on which mount hole is use when wheel is installed.

**For Warranty Information Visit:
www.balcrank.com**

Balcrank® Corporation
115 Reems Creek Rd.
Weaverville, NC 28787
800-747-5300
800-763-0840 Fax
www.balcrank.com

Service Bulletin SB4018
Rev. D 9/11

Revision Log:

Rev. D - Added dimension for bottom of
wheel to top of drain