

ENGINE SYSTEM

- Kubota® D1005
- Diesel fueled
- EPA Final Tier 4
- 3 cylinder
- 1.0 L displacement
- Liquid cooled
- Power @ 1,800 rpm – HP (kW):
 - Prime: 11.7 (8.7)
 - Standby: 13.1 (9.8)

Fuel System

- Polyethylene tank – 39.9 gal (151.04 L) capacity
- Run time – hr:
 - Lights only: 138*
 - 100% load: 59*
- Fuel consumption – gal/hr (L/hr):
 - Lights only: 0.29 (1.10)*
 - 100% load: 0.68 (2.57)*
- Exterior fill port diameter: 3.5 in (89 mm)

Cooling System

- Air filter: Dry type cartridge

Lubrication System

- Oil filter: Full flow, spin-on type
- 750-hr service interval

**Data based on engine manufacturer and field test data after 100-hr engine break-in period. Actual results may vary, according to factors such as age and maintenance of equipment, environmental conditions, and fuel density. For fuel and maintenance recommendations, see owner's manual.*

GENERATOR

- 60 Hz engine/generator
- Marathon Electric® brushless
- Up to 6 kW output
- 120/240 VAC, 20/30 A
- ± 6% capacitor voltage regulation

CONTROLS

- External, illuminated control panel with sealed switches
- 4-position key activated switch (off, run, glow, start)
- Digital hour meter
- Automatic shutdown for low oil pressure and high coolant temperature
- One switch controls all light fixtures



FLOODLIGHTS

- Four 296 W LED fixtures
- Aluminum and polymer housing
- Efficiency: 145 LPW
- Lm/fixture: 43,050
- Total lm: 172,200
- Coverage: 19,526 ft² (1,814 m²) @ 0.5 ft-c
- IP68 LED modules; IP65 rated drivers
- Fixture-mounted drivers

ELECTRICAL SYSTEM

- 30 A start trip breaker (ensures no-load condition exists at start-up)
- Floodlight circuits with sealed 10 A breakers
- Convenience receptacles with individual breakers:
 - One 120 VAC, 20 A, GFCI, duplex outlet (NEMA 5-20R type)
 - One 240 VAC, 30 A, twistlock outlet (NEMA L6-30R type)
- Wiring is sized and fused to required amperage draw
- 440 CCA wet cell battery

MAST

- Vertical operation and storage
- Maximum height: 23 ft (7 m)
- Five sections with polymer guides
- Ground-adjustable light fixtures
- Winch: Dual handle, manual crank
- Distinctive angled fixture mount for common light distribution
- Rotation: 359° range of motion, adjustable from ground during full extension
- Industrial black powder-coat finish
- Self-retracting, coiled mast cord

ENCLOSURE

- Hood:
 - Injection-molded with UV protected colorant
 - Flip-up design for ease of service
- Sound rating: 63 dB(A) at 23 ft (7 m) @ prime power
- Lifting point and fork pockets
- Multi-lingual operating and safety decals
- Illuminated license plate holder
- Document holder with owner's manual – includes AC and DC wiring diagrams

TRAILER

- Tubular steel frame
- 2 in (50.8 mm) ball hitch
- Three 1,200 lb (544 kg) tube-and-sleeve leveling jacks – lockable into stowed positions
- 7,800 lb (3,538 kg) safety chains with spring loaded safety hooks
- DOT approved LED lights: Tail, side, brake, and directionals
- 2,200 lb (998 kg) leaf spring axle
- Molded polyethylene fenders
- Tires: ST175/80D13, 6 ply
- Track width: 47 in (119.4 cm)

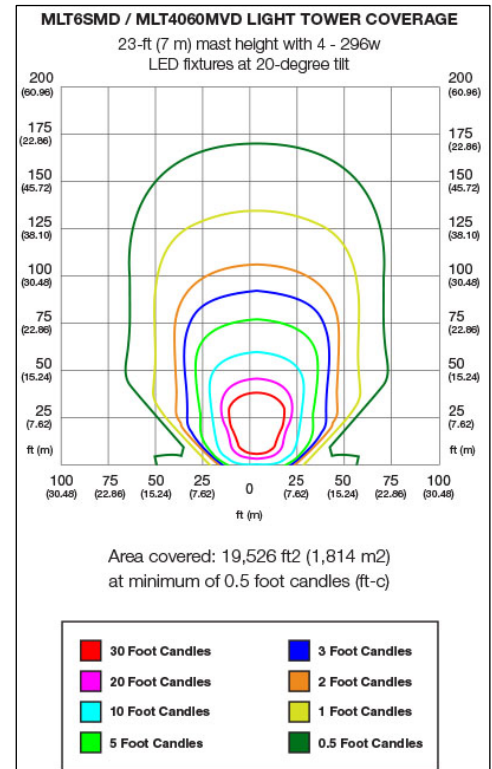

OPTIONS

- Electric winch
- Winch cover
- Positive air shutdown
- Tandem tow
- Battery charger
- Battery disconnect
- PowerZone® controller
- Telemetry
- Lower radiator hose heater
- Fuel filter heater

DIMENSIONS

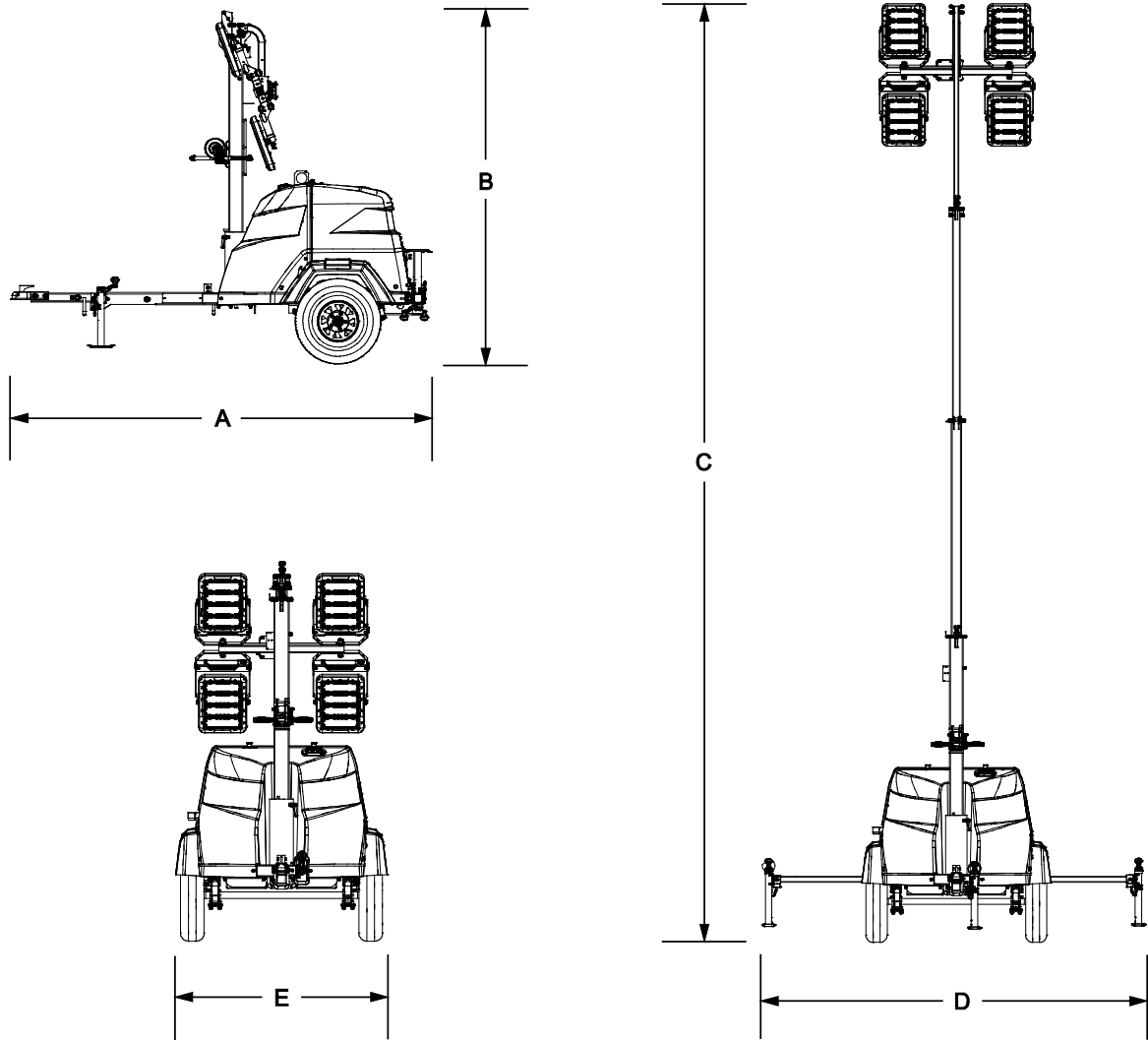

A	B	C	D	E
118 in (3 m)	101 in (2.6 m)	23 ft (7 m)	10 ft (3.05 m)	57 in (1.45 m)

WEIGHT

- Dry: 1,350 lb (612 kg)
- Operating: 1,620 lb (735 kg)

AMBIENT CLIMATE RATINGS

- Maximum wind speed: 65 mph (105 kph)
- Maximum air temperature – °F (°C):
 - Lights only: 120 (49)
 - 100% load: 104 (40)

WARRANTY

- Tower: 1 year, unlimited hours/2 years, 2,000 hours
- LED modules and drivers: 5 year limited warranty

CERTIFICATIONS

CSA approved, listed

FOR MORE INFORMATION

Owner's manual is available at www.generacmobileproducts.com/resources-tools/manuals.