



Hannay Reels®

The reel leader.

Hannay Reels, Inc.
553 State Route 143, Westerlo, NY 12193
www.hannay.com
Email: reels@hannay.com

Phone 1-518-797-3791
Toll Free 1-877-GO-REELS (467-3357)
Fax 1-800-REELING (733-5464)
Int'l Fax 1-518-797-3259

ISO 103 PARTS LIST

EPIV SERIES

Explosion Proof Motor Identification
Viewed from Motor Shaft End

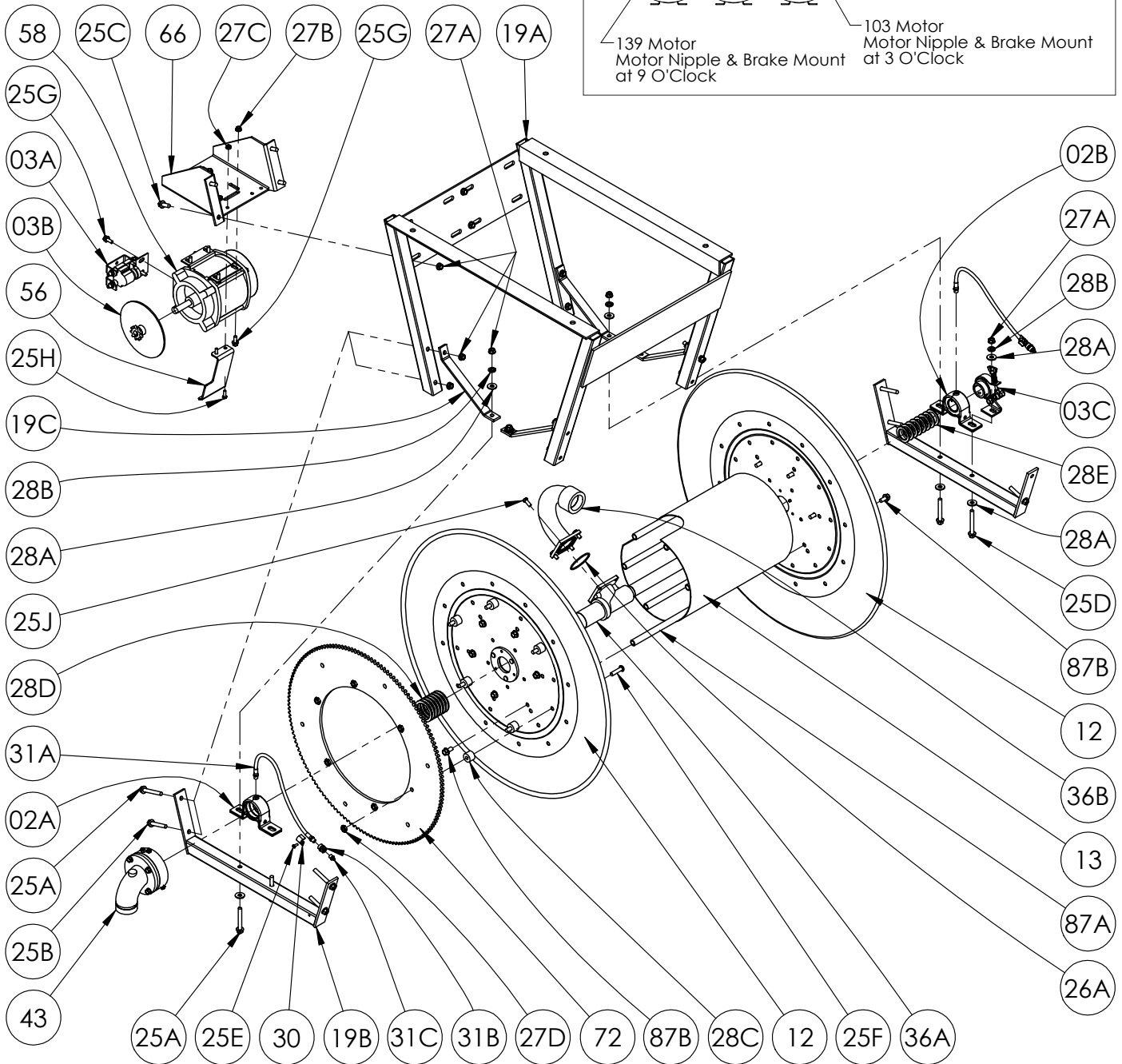
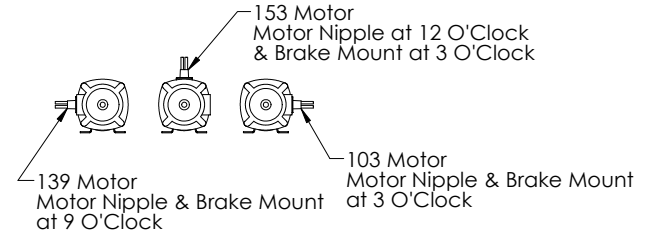

**PARTS LIST
ISO 103
EPIV Series**

**When Ordering Parts
BE SURE TO SPECIFY COMPLETE MODEL NUMBER and SERIAL NUMBER OF REEL
USE PART NUMBER!**

<u>Item No.</u>	<u>Description</u>	<u>Part No.</u>	<u>Quantity</u>
02A	1-1/2" Split Self Aligning Strap Bearing Complete (See ISO-211 For Parts)	9902.1612	1
02B	1" Back Bearing Complete (See ISO-211 For Parts).....	9902.1631	1
03A	Air Caliper Brake (P-38)	9947.0020	1
03B	Disc Brake with Sprocket, 9T40	9910.2100	1
03C	Comet Brake Assembly Complete (See ISO-212 For Parts).....	9947.0099	1
06	#40 Chain (Not Shown)	Specify Model	1
12	Disc.....	Specify Model/Serial #	2
13	Drum 10-1/2" or 15-1/2" Diameter	Specify Model	1
19A	Main EPIV Welded Frame Base (Less Top Rail).....	Specify Model	1
19B	EPIV Frame Rail (Bearing Mounting Piece Only).....	Specify Model	2
19C	Frame Brace.....	Specify Model	4
25A	3/8"-16 x 2-3/4" Long Spinlock Bolt	9904.2262	7
25B	3/8"-16 x 2-1/4" Long Spinlock Bolt	9904.2260	4
25C	3/8"-16 x 1" Long Spinlock Bolt	9904.2202	4
25D	3/8"-16 x 3" Long Hex Head Bolt.....	9904.1208	1
25E	#10 x 1/2" Self Tapping Hex Head Screw.....	9958.0001	2
25F	3/8"-16 x 1-1/2" Button Socket Bolt	9904.9203	6
25G	5/16"-18 x 3/4" Spinlock Bolt	9904.2201	6
25H	1/4"-20 x 3/4" Hex Head Bolt.....	9904.1001	2
25J	5/16"-18 x 3/4" Hex Head Bolt.....	9904.1101	4
26A	1-1/2" O-ring Gasket.....	9965.0028	1
26B	2" Riser O-Ring (not shown).....	9965.0027	1
27A	3/8"-16 Spinlock Nut.....	9904.6200	17
27B	5/16"-18 Spinlock Nut.....	9904.6100	4
27C	1/4"-20 Spinlock Nut.....	9904.6000	2
27D	3/8"-16 Hex Jam Nut	9965.0012	6
28A	3/8" Flat Washer	9954.0007	8
28B	7/16" Lock Washer	9954.0029	4
28C	Sprocket Spacers, per P28A-00330	9954.0015	6
28D	1-1/2" Hub Spacer, per P28A-00750	9954.0022	As Req'd
28E	1" Hub Spacer, per P28A-00360	9954.0021	As Req'd
28F	2" Hub Spacer (not shown)	9954.0023	As Req'd
29	Woodruff Key for Motor, 3/16" x 3/4" (Not Shown)	9916.0080	1
30	1/2" Cable Clamp, vinyl coated	9955.0015	2
31A	18" Braided Whip Grease Hose	9965.0100	2
31B	Female Coupling	9955.0302	2
31C	1/8" FNPT Grease Zerk.....	9965.0101	2
36A	1-1/2" Hub (Specify Model/Serial #)	9901.3640	1
36B	1-1/2" FNPT Flanged Riser (Specify Model/Serial #)	9901.3760	1
37A	2" Hub (not shown) (Specify Model/Serial #).....	9901.5640	1
37B	2" FNPT Riser (not shown) (Specify Model).....	9901.5760	1
43	1-1/2" 90° FxF Swivel Joint (WHJ-1590).....	9930.4220	1
44	2" 90° FxF Swivel Joint (not shown) (WHJ-290)	9931.4210	1
56	IV Series Brake Disc Guard, per P56A-00640 (Specify Model)	9947.0016	1
58	12V Electric Motor Base Mount (Specify Motor Nipple & Brake Location).....	Specify Model/Serial #	1
66	EPIV Motor Mounting Plate, per P66A-00190	9923.0030	1
72	146 Tooth #40 Disc Sprocket, 23-1/2" Dia.....	9910.3128	1
87A	Anodized Threaded Spacer Pipe.....	Specify Model	6
87B	3/8"-16 x 3/4" Spinlock Bolt (for use with Anodized Threaded Spacer Pipe).....	9904.2201	12