

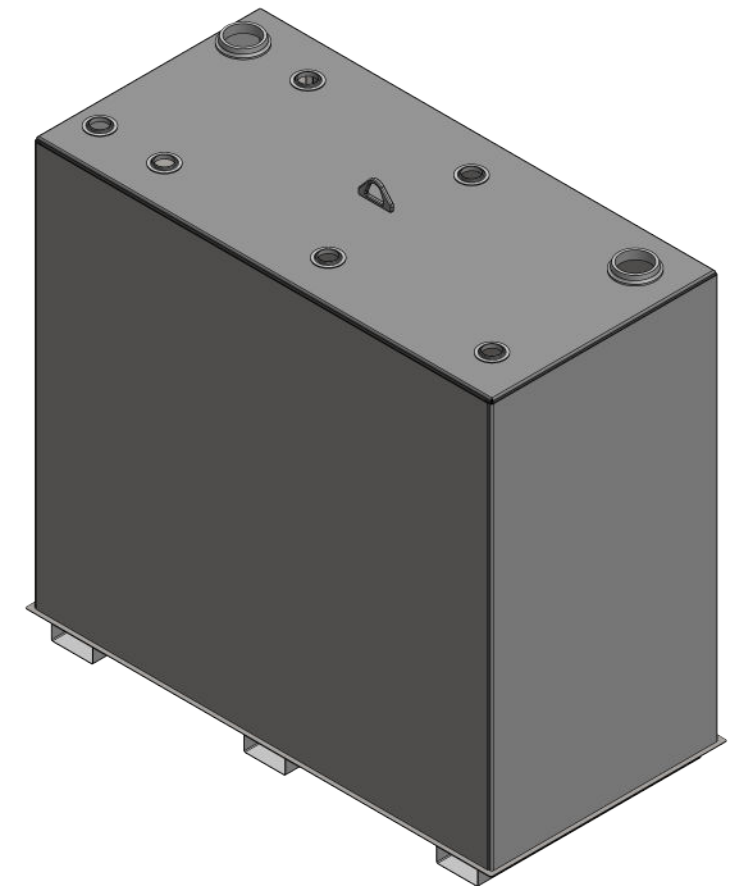

NOZZLE SCHEDULE							REMARKS
ITEM	SIZE	RATING	TYPE	MATL.	PROJ. IN	PROJ. OUT	
A	4"	N.P.T.	W.F.	C.S.	STD.	STD.	PRIMARY EMERGENCY VENT OPENING
B	4"	N.P.T.	W.F.	C.S.	STD.	STD.	SECONDARY EMERGENCY VENT OPENING
C	2"	N.P.T.	W.F.	C.S.	STD.	STD.	

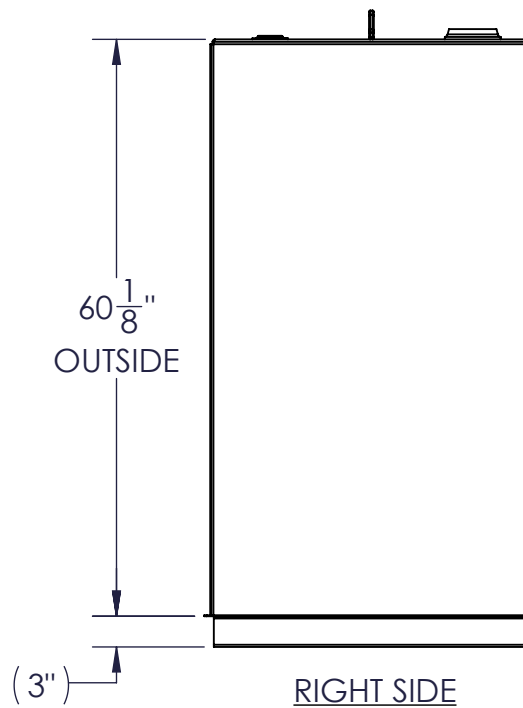
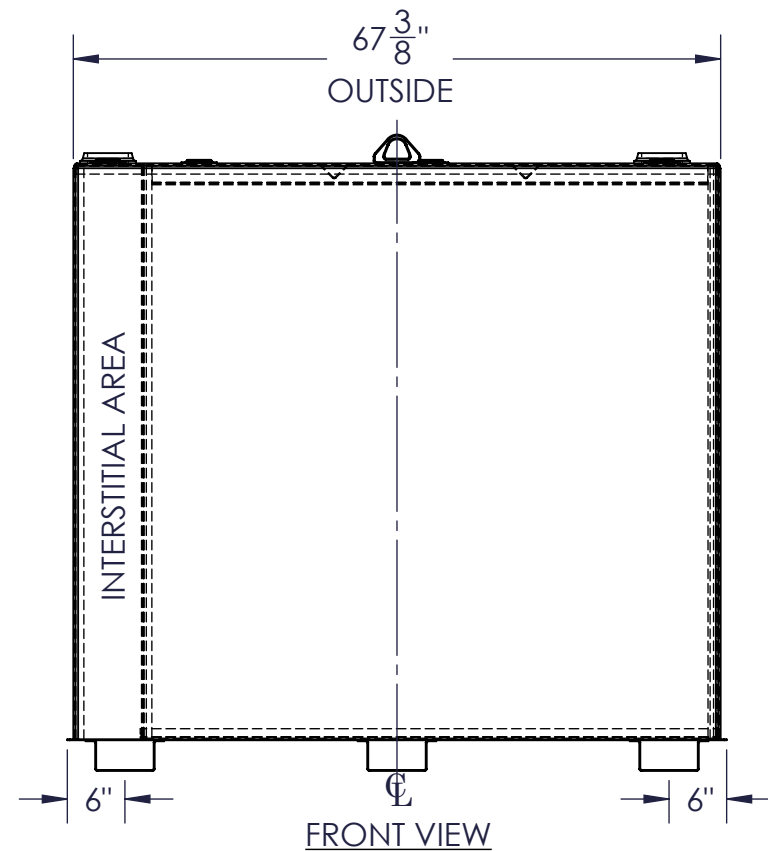
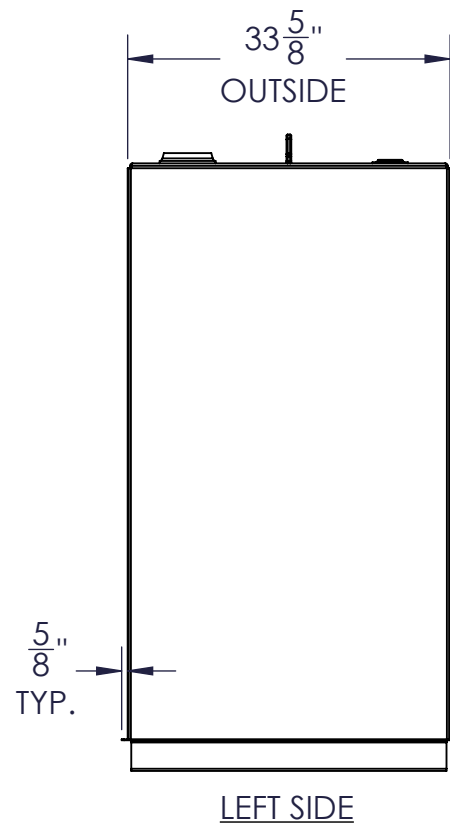

**NOTES:**

- A. MATERIAL: H.R. CARBON STEEL
- B. DESIGN & OPERATING PRESSURE: ATMOSPHERIC.
- C. DESIGN & OPERATING TEMPERATURE: AMBIENT.
- D. TANK TO BE BUILT & LABELED PER U.L. SPEC. #142.
- E. TANK TO BEAR MANUFACTURERS & U.L. LABELS ONLY.
- F. TANK TO BE AIR TESTED WITH WATER & SOAP SUDS SOLUTION.
- G. INTERIOR: REMOVE WELD SLAG (SHIP CLEAN & DRY).
- H. EXTERIOR: GRAY PRIMER INCLUDED; SEE SALES ORDER FOR TOP COAT.
- I. ALL FITTINGS TO BE PROTECTED FOR SHIPMENT.
- J. CUSTOMER HAS THE RESPONSIBILITY TO VERIFY ALL DIMENSIONS.

APPROVED AS DRAWN.  
 APPROVED WITH NOTED CHANGES, CONSTRUCTION WILL BE SCHEDULED WHEN SIGNED DRAWING AND CONFIRMED ORDER ARE RECEIVED.  
 SIGNATURE: \_\_\_\_\_  
 DATE: \_\_\_\_\_

SALES ORDER: -			WEIGHT (LBS): <b>981</b>
		<small>P.O. Box 246072 5700 West Bradley Road Milwaukee, WI 53224</small> <small>800-333-3331 PHONE</small> <small>info@jmesales.com EMAIL</small> <small>www.jmesales.com WEB</small>	
DESCRIPTION: <b>500 GALLON RECTANGULAR UL 142 DOUBLE WALL TANK</b>			
CUSTOMER:			P.O.#
DATE: 3/7/2023	SCALE:	DWG.# FTDBS-0500	DRAWN BY: <b>AJC</b> CHKD BY: -