

TOP VIEW

NOZZLE SCHEDULE						
ITEM	SIZE	RATING	TYPE	MATL.	REMARKS	NOTES
A	2"	N.P.T.	W.F.	C.S.	PRIMARY	SUCTION W/DROP TUBE
B	4"	N.P.T.	H. CPL.	C.S.	PRIMARY	EMERGENCY VENT
C	4"	N.P.T.	H. CPL.	C.S.	SECONDARY	EMERGENCY VENT
D	2"	N.P.T.	W.F.	C.S.	PRIMARY	UPDRAFT VENT
E	2"	N.P.T.	W.F.	C.S.	SECONDARY	THREAD PROTECTOR
F	1"	N.P.T.	W.F.	C.S.	SECONDARY	DIPSTICK
G	2"	N.P.T.	W.F.	C.S.	PRIMARY	AT-A-GLANCE GAUGE
H	2"	N.P.T.	W.F.	C.S.	PRIMARY	FILL BOX

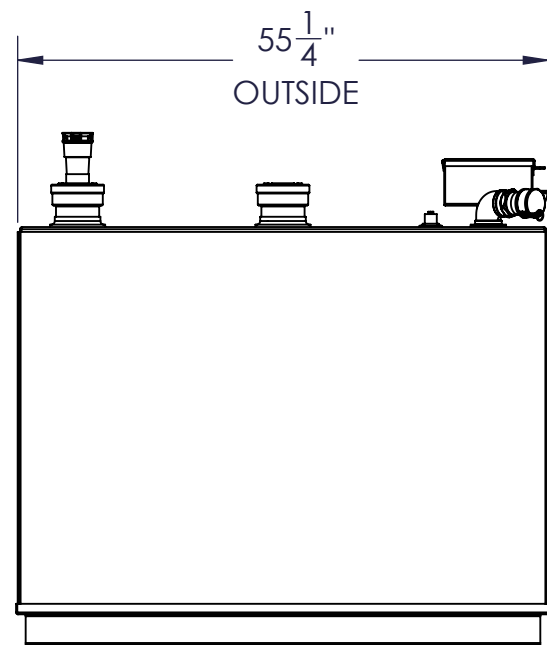

LEFT SIDE

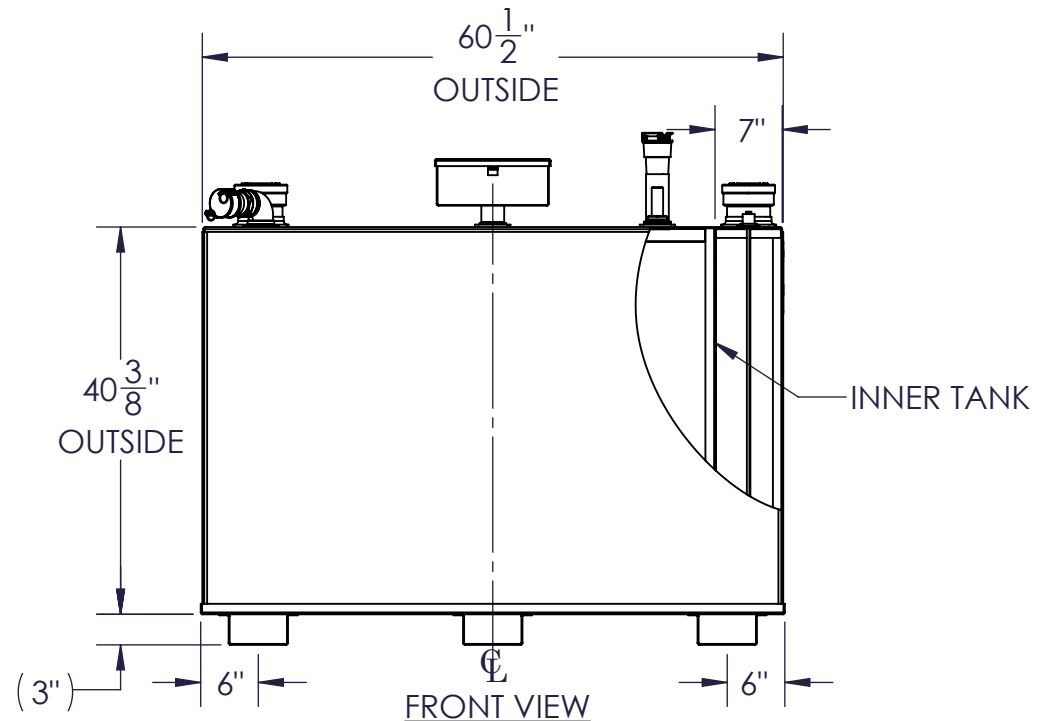

FRONT VIEW

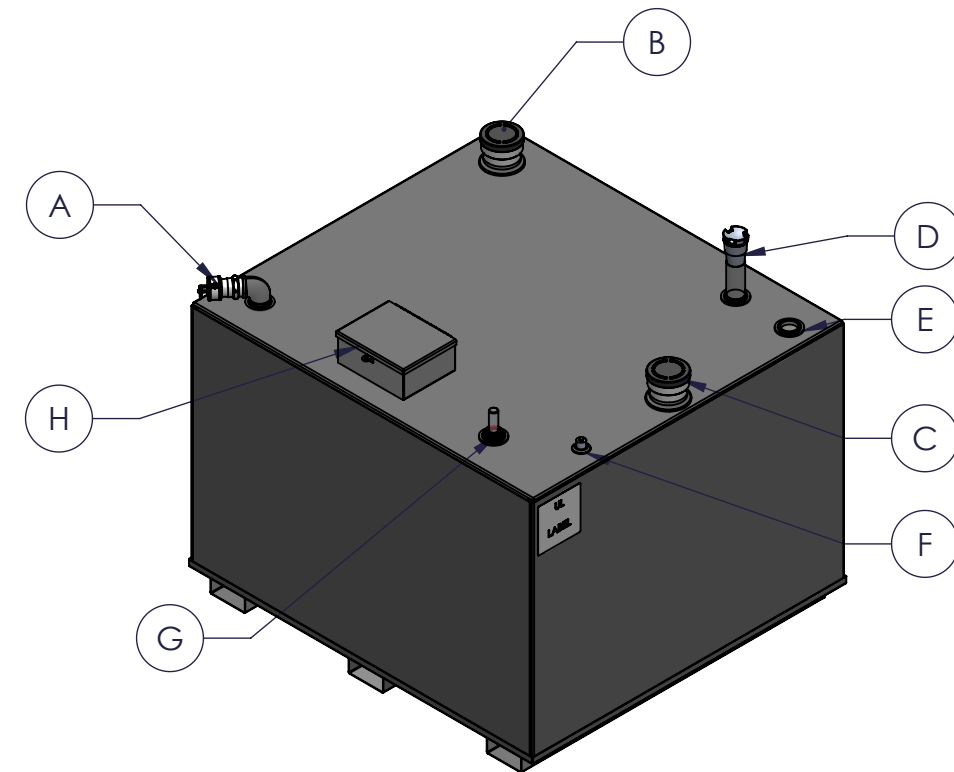

NOTES:

- A. QUANTITY:
- B. MATERIAL: H.R. CARBON STEEL
- C. INNER TANK/OUTER TANKS: 12 GA. W/10 GA. COMMON TOP.
- D. DESIGN & OPERATING PRESSURE: ATMOSPHERIC.
- E. DESIGN & OPERATING TEMPERATURE: AMBIENT.
- F. TANK TO BE BUILT & LABELED PER U.L. SPEC. #142.
- G. TANK TO BEAR MANUFACTURERS & U.L. LABELS ONLY.
- H. TANK TO BE AIR TESTED WITH WATER & SOAP SUDS SOLUTION.
- I. INTERIOR: REMOVE WELD SLAG (SHIP CLEAN & DRY).
- J. EXTERIOR: GRAY PRIMER INCLUDED; SEE SALES ORDER FOR TOP COAT.
- K. ALL FITINGS TO BE PROTECTED FOR SHIPMENT.
- L. CUSTOMER HAS THE RESPONSIBILITY TO VERIFY ALL DIMENSIONS.

APPROVAL FOR CONSTRUCTION  
SCHEDULE A - MASTER TERMS &  
CONDITION OF SALE\*

APPROVED AS DRAWN.

APPROVED WITH NOTED CHANGES,  
CONSTRUCTION WILL BE SCHEDULED  
WHEN SIGNED DRAWING AND  
CONFIRMED ORDER ARE RECEIVED.

SIGNATURE: \_\_\_\_\_

DATE: \_\_\_\_\_

SALES ORDER: -

WEIGHT (LBS): 974.0

**JME ELLSWORTH**  
John M. Ellsworth Co., Inc.

P.O. Box 240072  
8700 West Bradley Road  
Milwaukee, WI 53224

800-333-3331 PHONE  
info@mesales.com E-MAIL  
www.jme-sales.com WEB

All units inches  
unless stated  
otherwise

DESCRIPTION:  
500 GALLON RECTANGULAR UL 142 DOUBLE WALL TANK

CUSTOMER: \_\_\_\_\_ P.O.# \_\_\_\_\_

DATE: 11/2/2020 SCALE: \_\_\_\_\_ DWG.# FTDW-500 DRAWN BY: AJC

SHEET 1 OF 1