

# PETOL™ SURGRIP™ Friction Vises

## Operating Manual



© 2022 by PETOL. All rights reserved

Form ZVXX revision 08/15/2022

# Table of Contents

<b>PETOL™ SURGRIP™ Friction Vise Description .....</b>	<b>1</b>
<b>PETOL™ Limited Warranty .....</b>	<b>2</b>
<b>Safe Practices and Procedures .....</b>	<b>3</b>
Responsibility .....	3
Replacement Parts .....	3
Safety .....	4
Safe Practices .....	4
Safety Sources and Publications .....	4
Responsibility of Distributors .....	5
Overloading / Shock Loads / Side Loading .....	6
Environmental Conditions .....	6
<b>Operation .....</b>	<b>8</b>
Opening the Vise .....	8
Changing the Vise Bushing (if needed) .....	8
Closing the Vise .....	8
<b>ZV35-54 PETOL™ SURGRIP™ Friction Vise .....</b>	<b>9</b>
Dimensions .....	9
Torque and Diameter Capacity .....	10
ZV35-54 Parts List .....	11
ZV55-5-4A Bearing Nut Assembly Parts List .....	13
Wear Limits .....	14
<b>ZV55-54 PETOL™ SURGRIP™ Friction Vise .....</b>	<b>15</b>
Dimensions .....	15
Torque and Diameter Capacity .....	16
ZV55-54 Parts List .....	17
ZUV55-35A Adapter Bushing Assembly Parts List (optional) .....	19
Wear Limits .....	20

## **PETOL™ SURGRIP™ Friction Vise Description**

The PETOL™ SURGRIP™ Friction Vises were designed for holding downhole pump and other precision components during makeup and breakout operations where marking is prohibited.

The vises utilize precision aluminum bushings that can be quickly and easily installed in the jaws. The bushings are match-bored to a specific diameter. Additional diameters will require additional bushings. The vises use high strength, heat treated alloy steels for other components for rugged, dependable service and high-quality materials throughout for long life with the toughest jobs.

The ZV35-54 Friction Vise uses aluminum bushings to work individual diameters from 0.625 to 3.250 inches. The bushings and bushing keys may be removed to work 3.500-inch diameter. The vise incorporates a 4-inch clamping nut to tighten the vise. The vise is rated up to 7,700 foot-pounds of torque depending on diameter (see page 10).

The ZV55-54 Friction Vise uses aluminum bushings to work individual diameters from 3.000 to 5.250 inches. The bushings and bushing keys may be removed to work 5.500-inch diameter. The vise may be optionally equipped with ZUV55-35A adapter bushings to use ZUV35 bushings for smaller diameters. The vise incorporates a 4-inch clamping nut to tighten the vise. The vise is rated up to 27,700 foot-pounds of torque depending on diameter (see page 16).

# **PETOL™ Limited Warranty**

## **What Is Covered**

PETOL™ tools are expressly warranted to you, the purchaser, to be free of defects in material and workmanship.

## **How Long Coverage Lasts**

This express warranty lasts for the lifetime of the PETOL tool. Warranty coverage ends when the tool becomes unusable for reasons other than defects in workmanship or material.

## **How Can You Get Warranty Service**

To obtain the benefit of this warranty, contact a PETOL sales representative in Clifton, Texas.  
PETOL · 4450 S. Highway 6 · P.O. Box 192 · Clifton, TX 76634

## **What Will We Do To Correct Problems**

Warranted products will be repaired or replaced, at PETOL's option, and returned at no charge to you, the original purchaser; or, if after three attempts at repair or replacement during the warranty period, the product defect in material or workmanship persists, you can elect to receive a full refund of your original purchase price for the product.

## **What Is Not Covered**

Defects, failures or conditions that are due to normal wear and tear, abuse or misuse, are not covered by this limited warranty. In addition, this limited warranty is in lieu of all other warranties, express or implied, verbal or written. To the maximum extent allowed by law PETOL disclaims all implied warranties, including implied warranties of merchantability and/or fitness for a particular purpose. PETOL also specifically denies any liability for any incidental damages and/or consequential damages, including but not limited to property damage to property other than the product itself, loss of sales profits, down time, costs or any other damages measurable in money, whether or not included in the foregoing enumeration.

Please be advised that some states do not allow the exclusion or limitation of incidental or consequential damages, so this limitation or exclusion may not apply to you. This warranty gives you specific rights, and you may also have other rights, which vary from state to state, province to province, or country to country.

## **Are Personal Injuries Covered**

In the event you, someone working for you, or any other person sustain a personal injury as a result of using the PETOL tool, PETOL limits its potential liability for such a claim or injury to the fullest extent allowed by law, and disclaims and denies any liability for such personal injury.

Please be advised that some states do not allow the exclusion or limitation of liability for personal injuries, so the above limitation or exclusion may not apply to you, or the individual claiming injury.

## **No Other Express Warranty Applies**

This PETOL LIMITED WARRANTY is the sole and exclusive warranty, express or implied for PETOL products. No employee, agent, dealer or other person is authorized to alter, modify, expand or reduce the terms of this warranty or to make any other warranty on behalf of PETOL.

## **Law Applicable**

All matters related to the sale and/or use of the PETOL tool that is the subject of this limited warranty, along with the construction and enforcement of the terms of this limited warranty itself, shall be subject to the substantive and procedural laws of the state of Texas, not the conflicts of laws provisions of Texas, but rather the laws of Texas themselves.

**Forum Selection Clause**

Any dispute arising out of the sale and/or use of the PETOL tool that is the subject of this limited warranty shall be presented in the form of a claim or lawsuit to the offices of PETOL in Clifton, Bosque County, Texas. No claim or suit may be brought against PETOL, arising out of the sale and/or use of the tool, or arising out of the terms of this warranty, except in such forum. Purchase and/or use of the PETOL tool makes you subject to the benefits and limitations of this limited warranty. Accordingly, any writ, judgment or other enforcement, obtained from a jurisdiction, county, parish, state or federal court or other country, other than from the forum identified above, shall be void and unenforceable against PETOL.

**Arbitration Clause**

In the event of dispute or claim arises out of the sale and/or use of the PETOL tool that is the subject of this limited warranty, or arises out of the interpretation or enforcement of the terms and conditions of this limited warranty, such dispute shall be submitted to binding arbitration pursuant to the rules of the American Arbitration Association. If required to accomplish the purpose of this Arbitration clause, the purchaser hereby expressly waives any right to demand trial by jury.

**Complete Agreement**

This express limited warranty contains the entire agreement regarding express or implied warranties related to the PETOL tool that is the subject of it. No writing or language contained in the purchase order or any other document of the purchaser, or invoice of PETOL or any intermediate seller, shall be construed as modifying, in any way, the rights and liabilities contained in this limited warranty. PETOL expressly disclaims any obligations expressed in any customer purchase order or document that are contrary to the terms and limitations of this warranty.

**Severability**

If any term or limitation contained in this limited warranty is deemed unenforceable by law, then the term shall be severed from the remaining portions of the limited warranty which shall remain enforceable.

All communications to PETOL regarding the use of the tool and any aspect of the sale of the tool of this limited warranty should be addressed to PETOL.

PETOL · 4450 S. Highway 6 · P.O. Box 192 · Clifton, TX 76634

**Safe Practices and Procedures****Responsibility**

"It is the responsibility of the employer to train the employee in the proper selection and usage of tools, chains, etc., and to ensure that they are selected and used in that manner. In many instances, injury results because it is assumed that anybody knows how to use common hand tools. Observations and the record show that this is not the case. A part of every job instruction program should therefore be detailed training in the proper use of hand tools (and of all other special tools and equipment needed to accomplish the job)." - (Source: National Safety Council)

"Employers are responsible for the safe condition of tools and equipment used by employees, including tools and equipment which may be furnished by employees." - (Source: OSHA 1910.242A)

**Replacement Parts**

Use only PETOL™ replacement parts - no other parts are of comparable strength, quality and interchangeability.

## **Safety**

While we pride ourselves on the quality and dependability that we build into PETOL tools and products, we caution users that it is only prudent to know and follow the simple rules of safety when using our products, or anyone else's.

Always follow safe practices and procedures in accordance with the recommendations of OSHA, The National Safety Council (NSC), The Hand Tools Institute (HTI), The International Association of Drilling Contractors (IADC), Etc. All applicable Governmental rules, regulations or restrictions, now in effect or which may be promulgated, take precedence over the suggestions in this publication. The information in this publication is designed to supplement standard safe practices and procedures, not in lieu of, or replacement thereof.

### **Safe Practices**

#### **(Source: The National Safety Council)**

Failure to observe one or more of the following five safe practices accounts for most hand and powered tool accidents:

1. ALWAYS WEAR SAFETY GOGGLES TO PROTECT EYES
2. SELECT THE RIGHT TOOL FOR THE JOB
3. KEEP TOOLS IN GOOD CONDITION
4. USE TOOLS CORRECTLY
5. KEEP TOOLS IN A SAFE PLACE

Safety Goggles must always be worn by persons in any area where hand and powered tools are being used.

Never apply excess leverage to a wrench or tool by means of a "Cheater Bar". Never strike wrenches and tools with hammers or other objects.

All tools should be kept clean, inspected on a regular basis, and replaced when they show signs of wear.

Be especially careful not to place yourself in a position that could result in bodily injury in the event of a failure. Brace yourself firmly and pull rather than push when wrenching. (If necessary, to push, do so with the flat of the hand rather than gripping around the wrench.)

Never stand under or near loads being hoisted off the ground.

**READ SAFE PRACTICES AND PROCEDURES MANUAL, CATALOG INFORMATION AND PRODUCT LABELING PRIOR TO OPERATION.**

### **Safety Sources and Publications**

In the interest of Safety the following sources of Safety information is furnished:

The Hand Tools Institute (HTI)  
25 North Broadway  
Tarrytown, New York 10591  
(914) 332-0040  
www.hti.org

The National Safety Council (NSC)  
1121 Spring Lake Drive  
Itasca, Illinois 60143-3201  
(630) 285-1121  
www.nsc.org

International Safety Council  
1121 Spring Lake Drive  
Itasca, Illinois 60143-3201  
(630) 285-1121

### **Responsibility of Distributors**

IT IS THE RESPONSIBILITY OF THE PURCHASERS OF PETOL™ PRODUCTS TO CONVEY THE INFORMATION IN THIS PUBLICATION AND ANY OTHER INFORMATION RELATING TO THE INDIVIDUAL PRODUCT, THROUGH THE CHANNELS OF DISTRIBUTION, DOWN TO AND INCLUDING THE INDIVIDUAL USING THE PRODUCT

### **NOTE:**

**In view of the fact that the actual use determines whether safety requirements have been met, the ultimate responsibility to comply rests with the end user.**

## **Overloading / Shock Loads / Side Loading**

Attempting to “inch loads which are beyond the rated capacity of the tool.

Striking the tool with a hammer or other object while force is being exerted in an attempt to loosen a “frozen” joint.

Side pull can be caused by pulling or pushing on the tong in a direction that is not along a perpendicular plane, unlevelled mounting of the tong or vise, inadequate support of the part being broken out, and improper seating of the part being broken out in the tong or vise. Improper seating will occur when the diameter of the part is not consistent within the width of the tong or vise jaw.

## **Environmental Conditions**

Tools operate in widely varying environments, from wet outdoor conditions to mildly or highly corrosive industrial atmospheres. They can also be exposed to abrasives such as sand or grit.

The possible effects include:

Moisture - Corrosion and rust reduce strength by causing pitting and cracking.

Temperature - Very cold temperatures reduce strength by embrittlement.

Chemical Solutions or Vapors - Corrosive attack of the components' grain structure and/or the mechanical connections between the components (crevice corrosion) may occur. Cracking often is microscopic. Propagation to complete failure can be eventual or sudden.

Abrasives - Accelerated wearing and scoring of the articulating members (pins and jaws) may occur, with a corresponding reduction in strength. Due to inaccessibility of the bearing surfaces, wear and scoring are not readily noticeable.

These conditions, when coupled with normal wear and inherent residual stress, can result in environmentally assisted failure. It is impossible to predict vise life under complex conditions, as the degree of hostility and its effects are dependent on many variables such as temperature, time of exposure, concentration of corrosive atmosphere or medium, degree of abrasive wear, etc. Establishing the degree and frequency of unpredictable dynamic loading is also difficult.



## **Safety Precautions**

1. Always wear safety goggles to protect eyes.
2. Select the right tool for the job.
3. Keep tools in good condition.
4. Use tools correctly.
5. Keep tools in a safe place.
6. Wear protective clothing, gloves and safety shoes as appropriate.

## Operation

Refer to the diagram below for the components described in the operation. Torque should be applied clockwise in relation to the diagram.

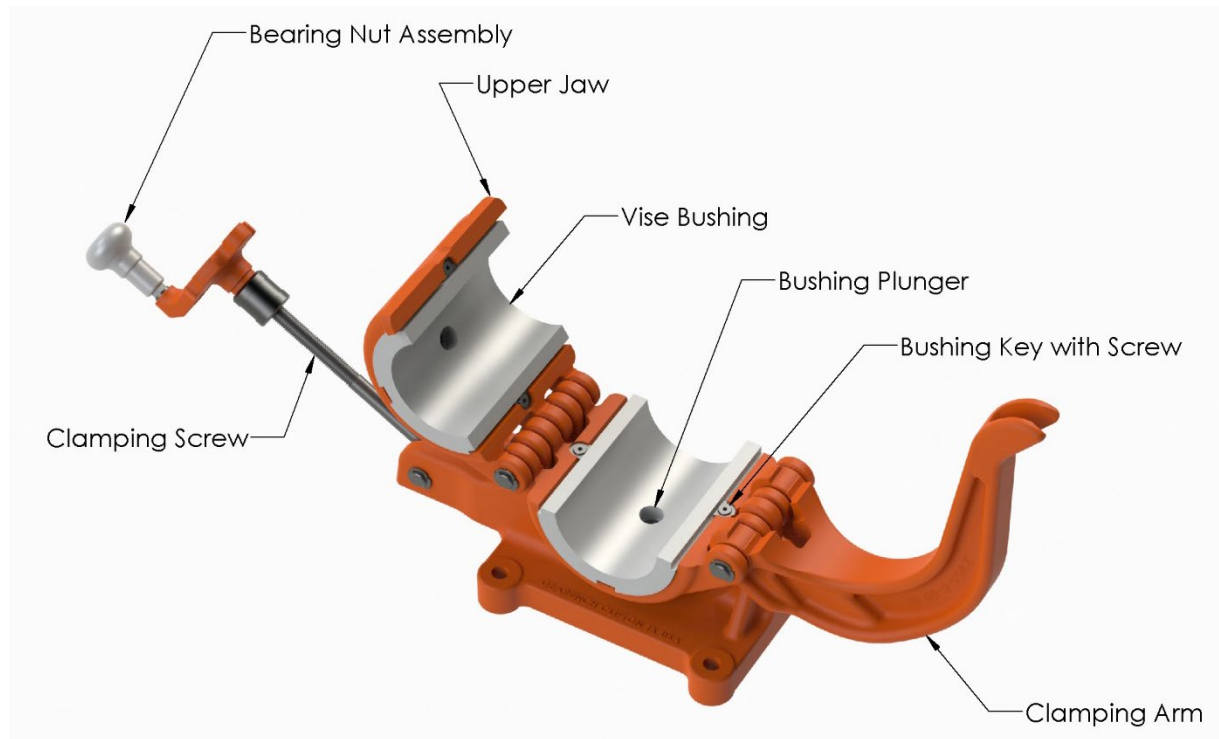

### Opening the Vise

1. Loosen the bearing nut assembly.
2. Swing the clamping screw with the bearing nut assembly away from the clamping arm.
3. Lift the clamping arm off of the upper jaw.
4. Lift the upper jaw to completely expose the vise bushings.

### Changing the Vise Bushing (if needed)

1. Press the bushing plunger through the hole in the vise bushing.
2. While the plunger is depressed, slide the bushing clear of the bushing keys.
3. Set appropriate bushing in the jaw.
4. Slide the bushing into the jaw until the plunger engages the bushing.

### Closing the Vise

1. Place the workpiece into the lower bushing.
2. Close the upper jaw until the bushing rests on the workpiece.
3. Swing the clamping arm fully towards the clamping screw.
4. Pivot the clamping screw and the bearing nut assembly until the screw is in the slot in the end of the clamping arm.
5. Tighten the bearing nut assembly against the clamping arm.

# ZV35-54 PETOL™ SURGRIP™ Friction Vise

## Dimensions

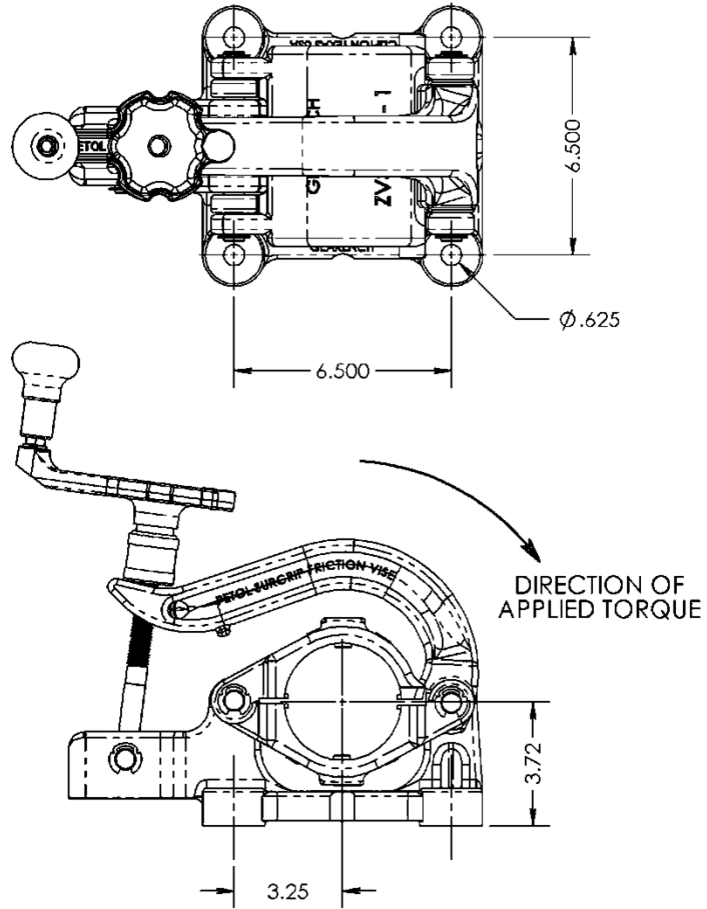

### **Torque and Diameter Capacity**

The following table lists the maximum working torques for the diameter range of the vise.

<b>Diameter Range</b>	<b>Maximum Torque (foot-pounds)</b>
0.625 – 1.004	1,230
1.005 – 1.454	2,000
1.455 – 1.874	3,000
1.875 – 2.264	4,000
2.265 – 2.634	5,000
2.635 – 2.984	6,000
2.985 – 3.219	7,000
3.220 – 3.500	7,700

**WARNING:** Under no circumstances should the maximum working load be exceeded. Overloading may result in injury or death. Always use a load cell or other calibrated indicating device to monitor the line pull on the tong to avoid an overload.

## ZV35-54 Parts List

The following drawings, diagrams, and parts lists describe all parts, which may be needed as replacement items.

**All vise components are manufactured only by PETOL™. DO NOT ATTEMPT TO SUBSTITUTE THESE COMPONENTS. The vise will not work properly unless these components are matched to the specific application. Consult our factory as your requirements change. Any non-PETOL substitutions of these components void all warranties and subject the user to assumption of liabilities resulting from subsequent use.**

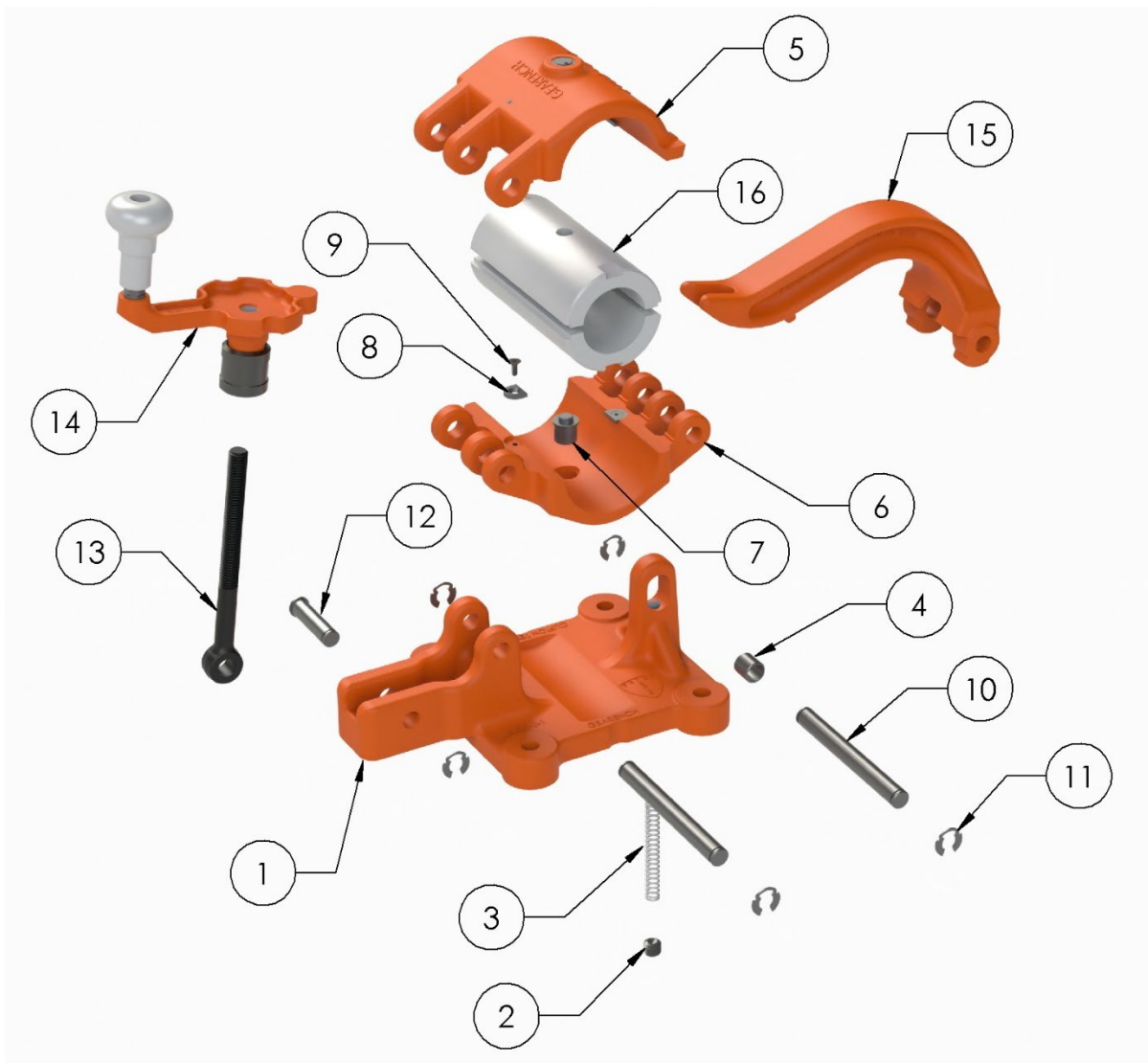

<b>Item</b>	<b>Qty.</b>	<b>Part Number</b>	<b>Description</b>
1	1	ZV35-0-1	Base
2	1	ZV35-0-4	Base set screw
3	1	HS07	Base spring
4	1	HU50	Base spring bushing
5	1	ZV35-4-1	Upper jaw
6	1	ZV35-4-2	Lower jaw
7	2	ZV35-8	Vise bushing plunger
8	4	ZV35-10-1	Vise bushing key
9	4	ZV35-10-2	Vise bushing key screw
10	2	HP030	Jaw pin with kliprings
11	5	HXKR062	Klipring only
12	1	HP007	Clamping screw pin with klipring
13	1	ZV35-9-78	Clamping screw
14	1	ZV55-5-4A	Bearing nut assembly (see page 12)
15	1	ZV35-6-00	Clamping arm (standard)
15	1	ZV35-6-60	Clamping arm (0.060 oversize)
15	1	ZV35-6-120	Clamping arm (0.120 oversize)
16	1	ZUV35:X.XXX	Vise bushing set (X.XXX = diameter)

## ZV55-5-4A Bearing Nut Assembly Parts List

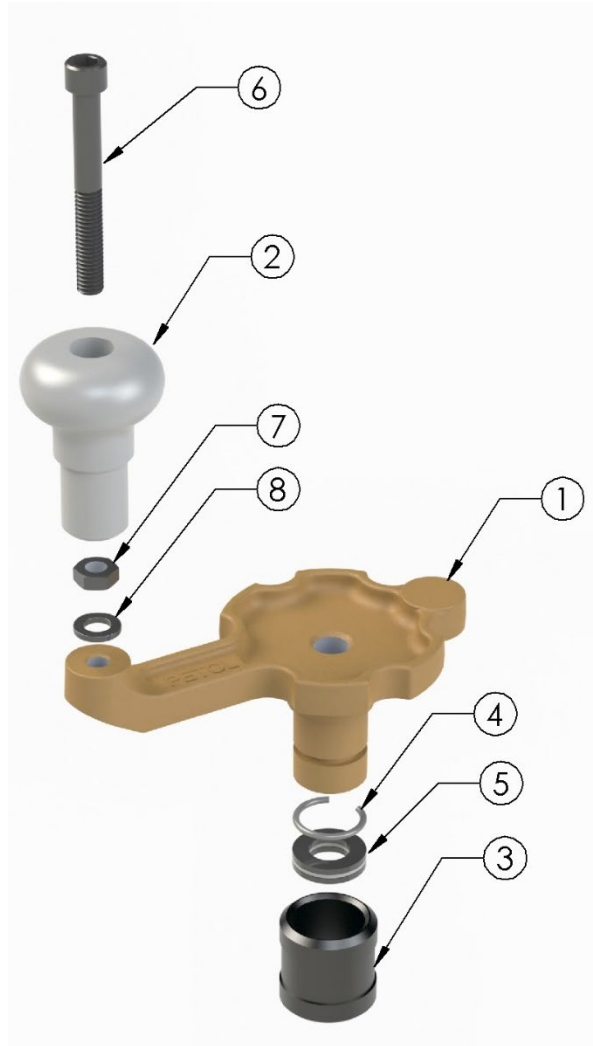

Item	Qty.	Part Number	Description
1	1	ZV55-5-40	Handle
2	1	ZV35-5-21	Grip
3	1	ZV35-5-27	Sleeve
4	1	ZV35-5-28	Clip ring
5	1	ZV35-5-29R	Bearing
6	1	HB53	Socket head cap screw
7	2	HXN020	Jam nut
8	4	HXW006	Spring lock washer

## Wear Limits

The following table indicates the limiting dimensions on the components of the PETOL™ SURGRIP™ Friction Vise. When localized wear is beyond any one of the limits indicated, the component should be replaced.

<b>Part Number</b>	<b>Description</b>	<b>Location</b>	<b>Limit Dimension</b>
ZV35-0-1	Base	Jaw pin hole	0.645 (max)
ZV35-0-1	Base	Clamping screw pin hole	0.645 (max)
ZV35-4-1	Upper jaw	Jaw pin hole	0.645 (max)
ZV35-4-2	Lower jaw	Jaw pin hole	0.645 (max)
ZV35-6-00	Clamping arm	Jaw pin hole	0.645 (max)
ZV35-6-00	Clamping arm	Contact with upper jaw	Use oversize arm
ZV35-9-78	Clamping screw	Pin hole	0.645 (max)
HP030	Jaw pin	Pin body	0.614 (min)
HP007	Clamping screw pin	Pin body	0.614 (min)



# ZV55-54 PETOL™ SURGRIP™ Friction Vise

## Dimensions

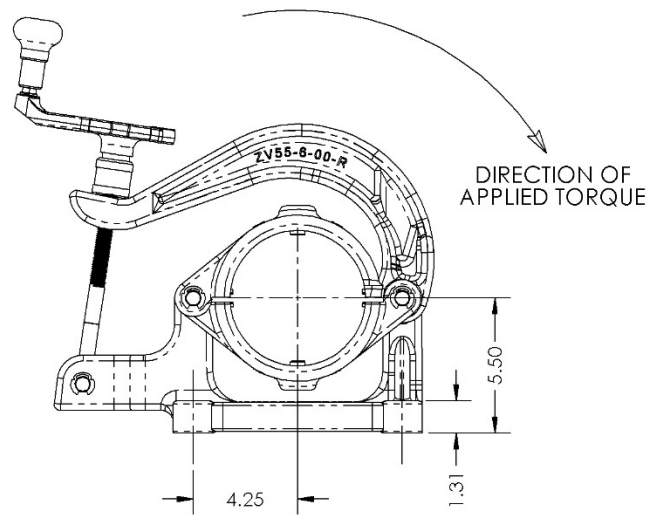
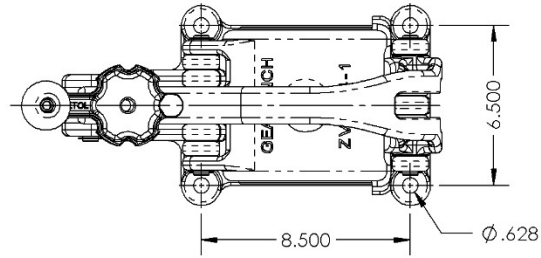

### **Torque and Diameter Capacity**

The following table lists the maximum working torques for the diameter range of the vise.

<b>Diameter</b>	<b>Maximum Torque (foot-pounds)</b>
0.625 – 1.029	2,300
1.030 – 1.709	4,000
1.710 – 2.339	7,000
2.340 – 3.259	10,000
3.260 – 4.099	15,000
4.100 – 4.859	20,000
4.860 – 5.249	25,000
5.250 – 5.500	27,700

**WARNING:** Under no circumstances should the maximum working load be exceeded. Overloading may result in injury or death. Always use a load cell or other calibrated indicating device to monitor the line pull on the tong to avoid an overload.

### ZV55-54 Parts List

The following drawings, diagrams, and parts lists describe all parts, which may be needed as replacement items.

**All vise components are manufactured only by PETOL™. DO NOT ATTEMPT TO SUBSTITUTE THESE COMPONENTS. The vise will not work properly unless these components are matched to the specific application. Consult our factory as your requirements change. Any non-PETOL substitutions of these components void all warranties and subject the user to assumption of liabilities resulting from subsequent use.**

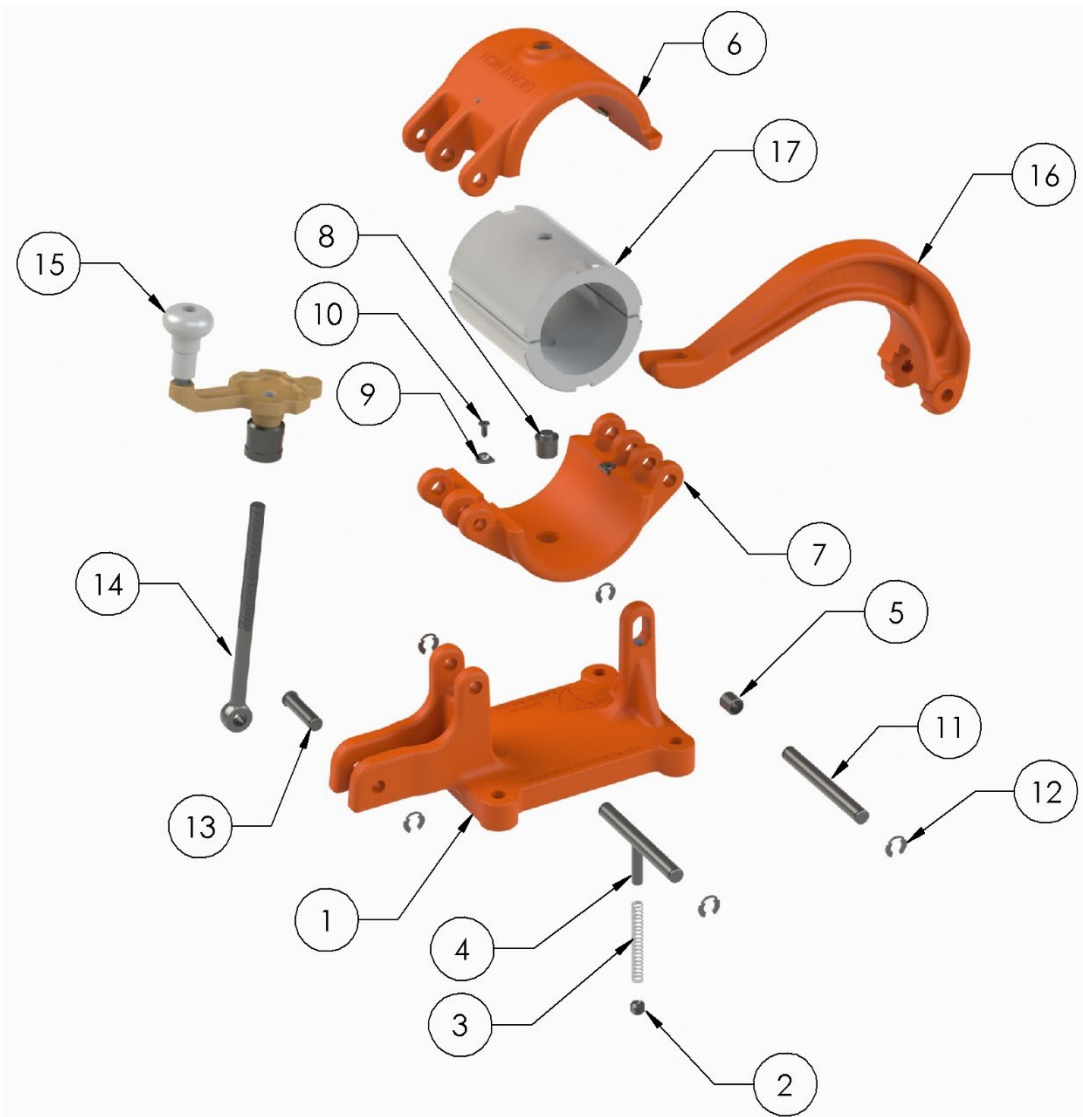

<b>Item</b>	<b>Qty.</b>	<b>Part Number</b>	<b>Description</b>
1	1	ZV55-0-1	Base
2	1	ZV35-0-4	Base set screw
3	1	HS07	Base spring
4	1	HG14	Base spring guide
5	1	HU50	Base spring bushing
6	1	ZV55-4-1	Upper jaw
7	1	ZV55-4-2	Lower jaw
8	2	ZV55-8	Vise bushing plunger
9	4	ZV35-10-1	Vise bushing key
10	4	ZV55-10-2	Vise bushing key screw
11	2	HP030	Jaw pin with kliprings
12	5	HXKR062	Klipring only
13	1	HP007	Clamping screw pin with klipring
14	1	ZV55-9-10	Clamping screw
15	1	ZV55-5-4A	Bearing nut assembly (see page 12)
16	1	ZV55-6-00	Clamping arm (standard)
16	1	ZV65-6-60	Clamping arm (0.060 oversize)
16	1	ZV65-6-120	Clamping arm (0.120 oversize)
17	1	ZUV55:X.XXX	Vise bushing set (X.XXX = diameter)

**ZUV55-35A Adapter Bushing Assembly Parts List (optional)**

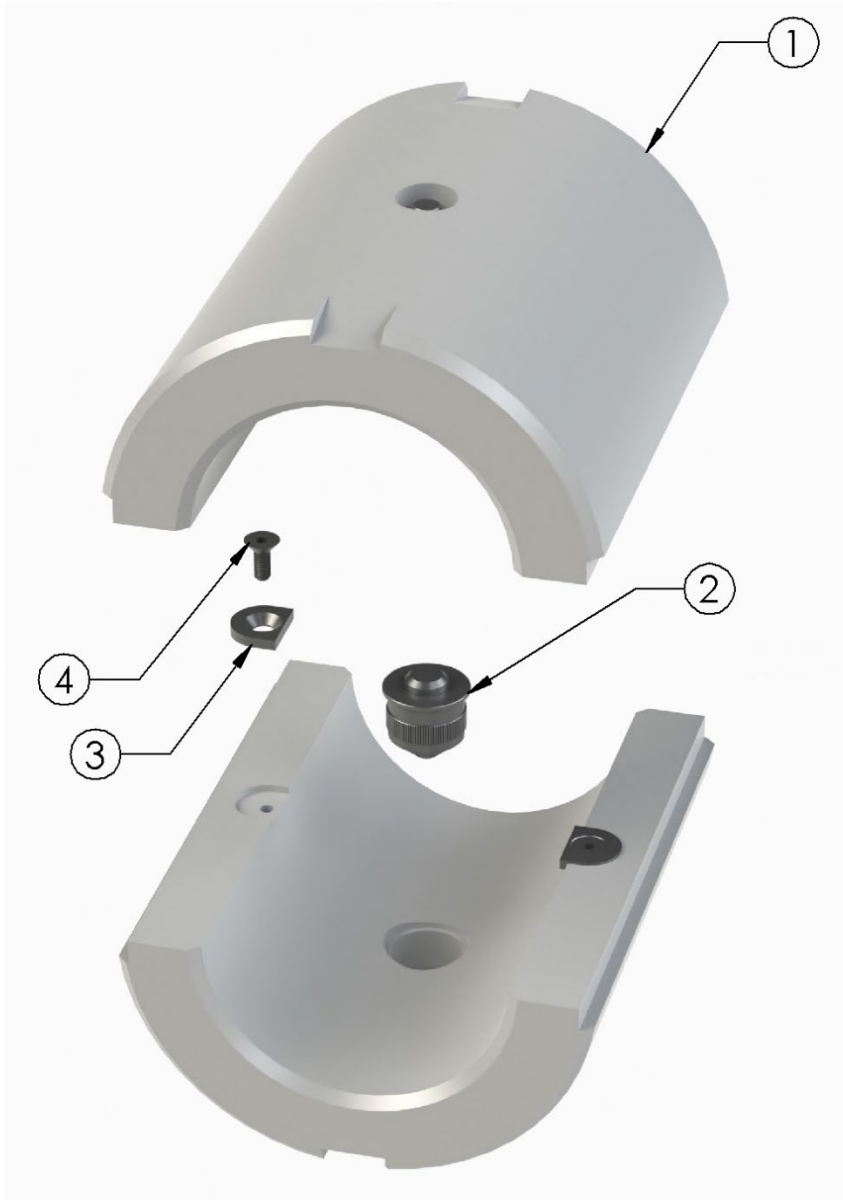

Item	Qty.	Part Number	Description
1	1	ZUV55-35A-I1	Adapter bushing
2	1	ZUV55-25B-8	Plunger assembly
3	1	ZV35-10-1	Bushing key
4	1	ZV35-10-2	Bushing key screw

## Wear Limits

The following table indicates the limiting dimensions on the components of the PETOL™ SURGRIP™ Friction Vise. When localized wear is beyond any one of the limits indicated, the component should be replaced.

<b>Part Number</b>	<b>Description</b>	<b>Location</b>	<b>Limit Dimension</b>
ZV55-0-1	Base	Jaw pin hole	0.645 (max)
ZV55-0-1	Base	Clamping screw pin hole	0.645 (max)
ZV55-4-1	Upper jaw	Jaw pin hole	0.645 (max)
ZV55-4-2	Lower jaw	Jaw pin hole	0.645 (max)
ZV55-6-00	Clamping arm	Jaw pin hole	0.645 (max)
ZV55-6-00	Clamping arm	Contact with upper jaw	Use oversize arm
ZV55-9-10	Clamping screw	Pin hole	0.645 (max)
HP030	Jaw pin	Pin body	0.614 (min)
HP007	Clamping screw pin	Pin body	0.614 (min)