



LUBE KITS



PUMPS



METERS



METERED NOZZLES



NOZZLES



FILTRATION

VISCOMAT VANE TOTE KIT

FEATURES

- ADJUSTABLE BYPASS
- MULTI-PURPOSE PUMP
- SUITABLE TO TRANSFER WASTE OILS

The Piusi VISCOMAT VANE is an electric vane pump suitable for transferring low and medium viscosity fluids. The pump is equipped with a built-in adjustable bypass.

PERFORMANCE

up to
500
cSt
VISCOSITY

up to
7 GPM
FLOW RATE

BELOW
77 DB

NOISE LEVEL**



VISCOMAT VANE TOTE KIT



PACKAGING

PART #	WEIGHT		PACKAGING				
	KG	LBS	MM	INCH	PCS/PALLET	PCS/BOX	
FOO248000	14.15	31.1	483X381X285	19X15X11	60	72	1



FLUID MONITORING



HOSE REELS



AIR



ANTIFREEZE



DEF



BIODIESEL



DIESEL



FOOD



GASOLINE



GREASE



KEROSENE



OIL



WATER



WINDSCREEN

CHARTS

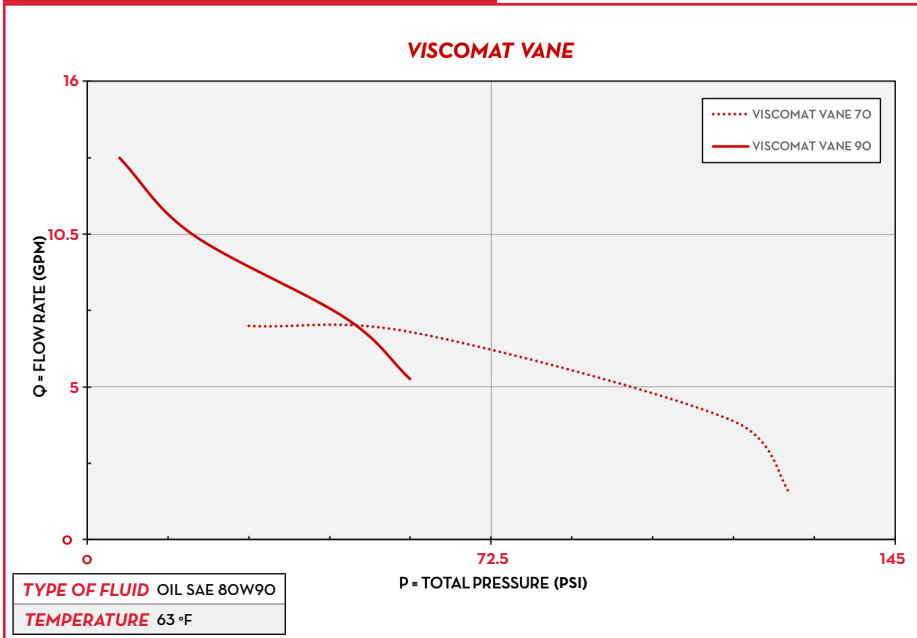

IN THE BOX

- VISCOMAT 70 VANE PUMP
- 13 FT. DELIVERY HOSE
- 6.5 FT SUCTION HOSE
- STAINLESS STEEL TOTE BRACKET
- EASYOIL MANUAL NOZZLE
- NOZZLE HOLDER
- SUCTION VALVE AVAILABLE ON REQUEST
- INSTRUCTION MANUAL

DETAILS

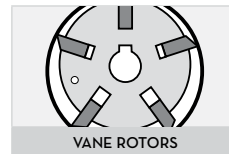

VANE ROTORS



ON/OFF SWITCH



ADJUSTABLE BYPASS

DIMENSIONS

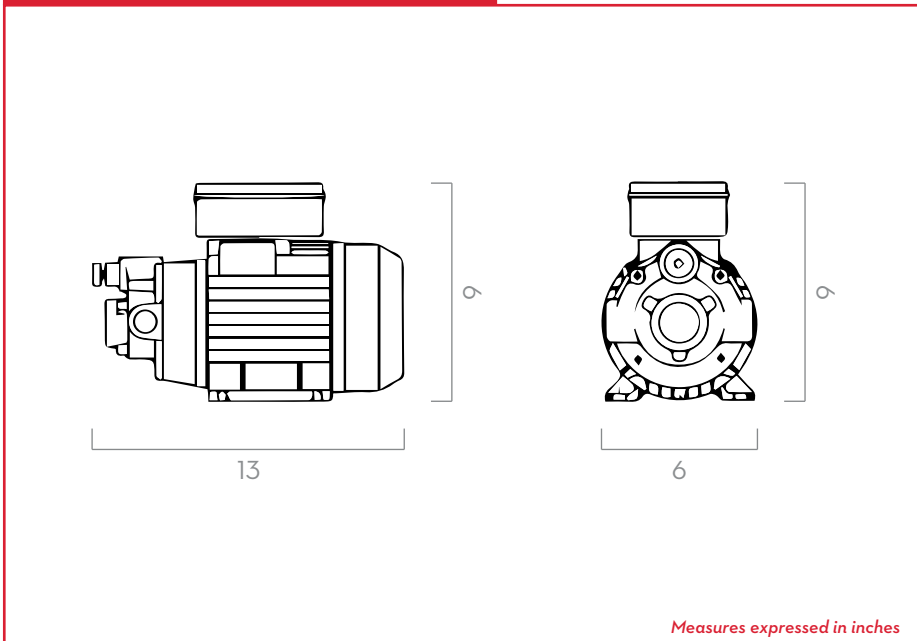

MATERIALS

- BODY: CAST IRON
- ROTOR: SINTERED STEEL
- VANES: TECHNOPOLYMER
- SHAFT: STEEL

TECHNICAL DATA

PART #	DESCRIPTION	FLUIDS TYPE	FLOW RATE		WORKING PRESSURE		VOLTAGE				RPM	INLET BSP	OUTLET NPT	BYPASS VALVE
			L/MIN	GPM	BAR	PSI	SINGLEPHASE MOTOR V./HZ	THREEPHASE MOTOR V./HZ	POWER WATT	AMP. MAX				
FOO248000	VISCOMAT 70 IBC KIT 120V/60HZ 7GPM		25	7	3	44	120/60	-	850	10	1700	1"	1/2"	YES

UPON REQUEST IT IS AVAILABLE WITH DIFFERENT VOLTAGE AND FREQUENCY
(*) WITHOUT ADJUSTABLE BYPASS VALVE

VISCOMAT VANE TOTE KIT