



FUEL MANAGEMENT SYSTEM



DISPENSERS



KITS



PUMPS



METERS



NOZZLES

PANTHER EX

FEATURES

- STURDINESS
- UNRIVALED FLOW-RATE
- EASE OF USE
- NEW TANK CONNECTION
- LONG-LASTING DURABILITY

The new PIUSI-branded **AC PANTHER EX** pump series is designed to meet the most demanding customers who need robust and reliable pumps capable of delivering unique performance. Years of research and study of diverse fueling applications have enabled PIUSI to develop this innovative pump. Capable of providing the highest flow rate of its class, it outperforms even while using a range of accessories. The PANTHER EX is available in a **16 GPM and 20 GPM** version to power fast refilling of large tanks.

PERFORMANCE

UP TO 20 GPM	120/60HZ
FLOW RATE	VOLTAGE
CONTINUOUS DUTY	MAX. 120 oF
DUTY CYCLE	AMBIENT TEMPERATURE



PANTHER EX 56



PANTHER EX 72

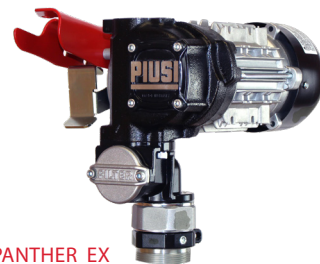

PANTHER EX



PACKAGING

CODE	WEIGHT		PACKAGING			N. BOXES / EUROPALLET	
	KG	LBS	MM	INCH	PCS/BOX		
PANTHER EX 56							
F0058050P2300	12,4	27,3	400X240X350	15,7X9,4X13,7	1	-	-
RKPEX56K33							
RKPEX56K33L							
PANTHER EX 72							
F0058150P2300	12,4	27,3	400X240X350	15,7X9,4X13,7	1	-	-
RKPEX72K150							
RKPEX72K150L							



FILTRATION



TANK MONITORING



HOSE REELS



ACCESSORIES



MERCHANDISE

PIUSI

CHART

PANTHER EX 56 / PANTHER EX 72

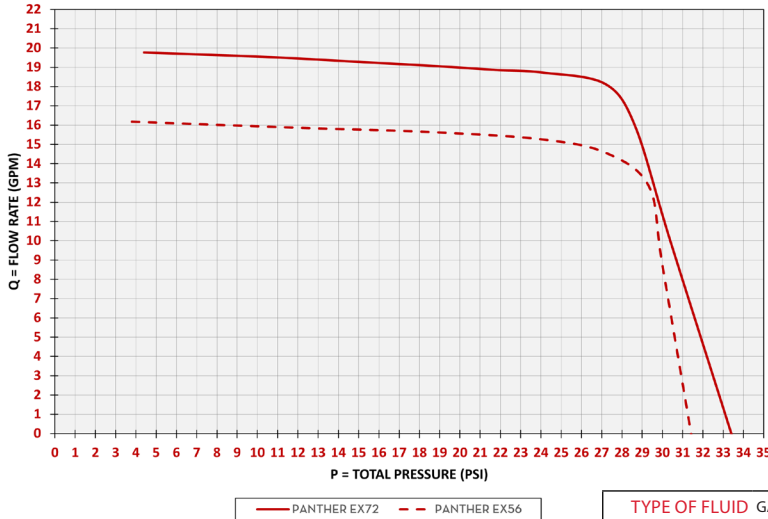

DIMENSIONS

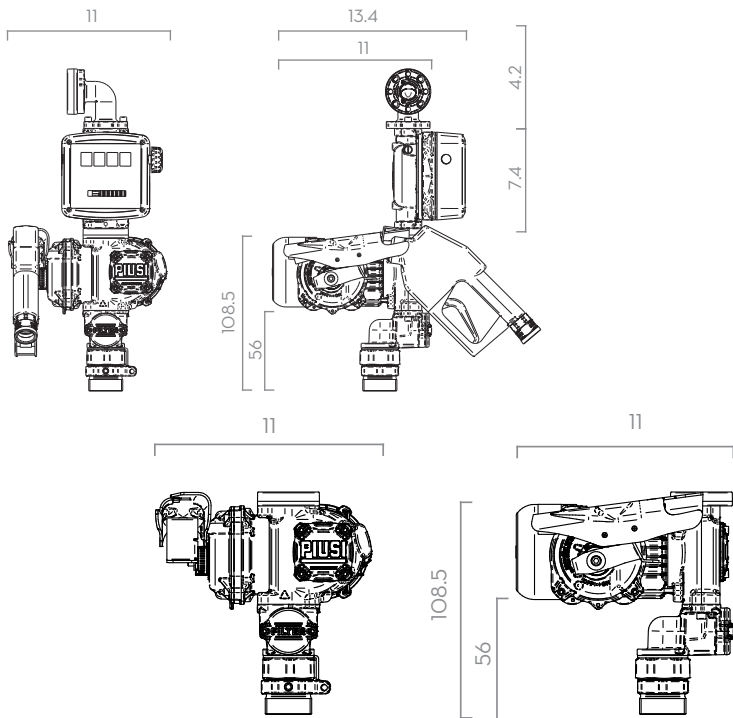

TYPE OF FLUID GASOLINE
TEMPERATURE 35,6°F

IN THE BOX

- PANTHER EX
- K33 METER (FOR 16GPM PUMP+METER KIT)
- K150 METER (FOR 20GPM PUMP+METER KIT)
- EASY LOCK CONNECTION
- INSTRUCTION MANUAL

DETAILS

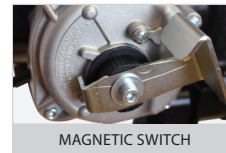

MATERIALS

- BODY: CAST IRON
- ROTOR: SINTERED STEEL
- VANES: TECHNOPOLYMER
- SHAFT: STEEL

Dimensions expressed in inches

TECHNICAL DATA

CODE	DESCRIPTION	FLUIDS TYPE	FLOW RATE		VOLTAGE			METER TYPE	INLET FILTER
			L/MIN	GPM	SINGLEPHASE MOTOR V./HZ	POWER HP	AMP. MAX.		
PANTHER EX 56									
F0058050P2300	(UL) PANTHER EX 56 120V 60HZ - PUMP ONLY	D G K	60	16	120/60 HZ	3/4	7,5	-	YES
RKPEX56K33	PANTHER EX56+K33 GALLON METER KIT 16GPM, 120V UL - CONTINUOUS	D G K	60	16	120/60 HZ	3/4	7,5	K33	YES
RKEX56K33L	PANTHER EX56+K33 LITER METER KIT 16 GPM, 120V UL - CONTINUOUS	D G K	60	16	120/60HZ	3/4	7,5	K33	YES
PANTHER EX 72									
F0058150P2300	(UL) PANTHER EX 72 120V 60HZ - PUMP ONLY	D G K	72	20	120/60 HZ	3/4	7,5	-	YES
RKPEX72K150	PANTHER EX72+K150 GALLON METER KIT 20GPM, 120V UL - CONTINUOUS	D G K	72	20	120/60 HZ	3/4	7,5	K150	YES
RKPEX72K150L	PANTHER EX72+K150 LITER METER KIT 20 GPM, 120V UL - CONTINUOUS	D G K	72	20	129/60HZ	3/4	7,5	K150	YES