

Turbine Series - 900FH/1000FH

FUEL

Specifications:

Height: 900FH: 16.5" (41.9 cm)
1000FH: 21.8" (55.4 cm)

Width: 5.96" (15.1 cm)

Depth: 5.96" (15.1 cm)
with Bracket 6.32" (16.1 cm)

Weight: 900FH: 6.0 lbs (2.7 kg)
1000FH: 10 lbs (4.5 kg)

Ports: 7/8"-14 UNF-2B (SAE J1926)

Service Clearance (Top): 900FH: 5.0" (12.7 cm)
1000FH: 10.0" (25.4 cm)

Vacuum Installation Recommended
Maximum Pressure: 15 psi (1.03 bar)

Max Flow Rate: 900FH: 90 gph (341 lph)
1000FH: 180 gph (681 lph)

Create a Part Number

Housing Type		Heater Option		Filtration Rating		
Turbine Model 90 GPH Flow Rate	Turbine Model 180 GPH Flow Rate	12 VDC Heater (325 watt)	24 VDC Heater (325 watt)	2 micron	10 micron	30 micron
900FH	1000FH	312	324	2	10	30

RACOR®

Dimensions:

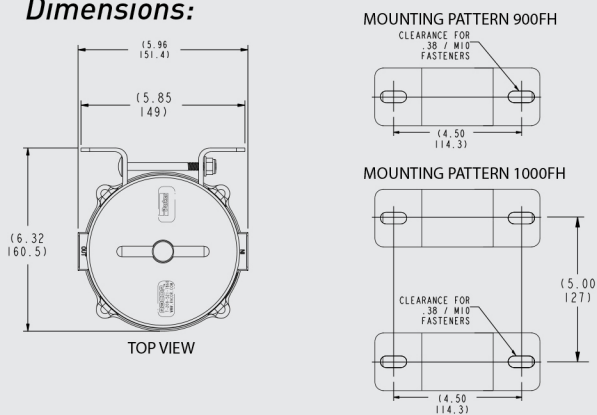

ASSEMBLY	DESCRIPTION
900FH2	900 Turbine Assy., 2 micron Filter
900FH10	900 Turbine Assy., 10 micron Filter
900FH30	900 Turbine Assy., 30 micron Filter
900FH31230	900 Turbine Assy., 12VDC Heater, 30 micron Filter
900FH32430	900 Turbine Assy., 24VDC Heater, 30 micron Filter
1000FH2	1000 Turbine Assy., 2 micron Filter
1000FH10	1000 Turbine Assy., 10 micron Filter
1000FH30	1000 Turbine Assy., 30 micron Filter
1000FH3122	1000 Turbine Assy., 12VDC Heater, 2 micron Filter
1000FH31210	1000 Turbine Assy., 12VDC Heater, 10 micron Filter
1000FH31230	1000 Turbine Assy., 12VDC Heater, 30 micron Filter
1000FH3242	1000 Turbine Assy., 24VDC Heater, 2 micron Filter
1000FH32430	1000 Turbine Assy., 24VDC Heater, 30 micron Filter

SINGLE ASSEMBLY

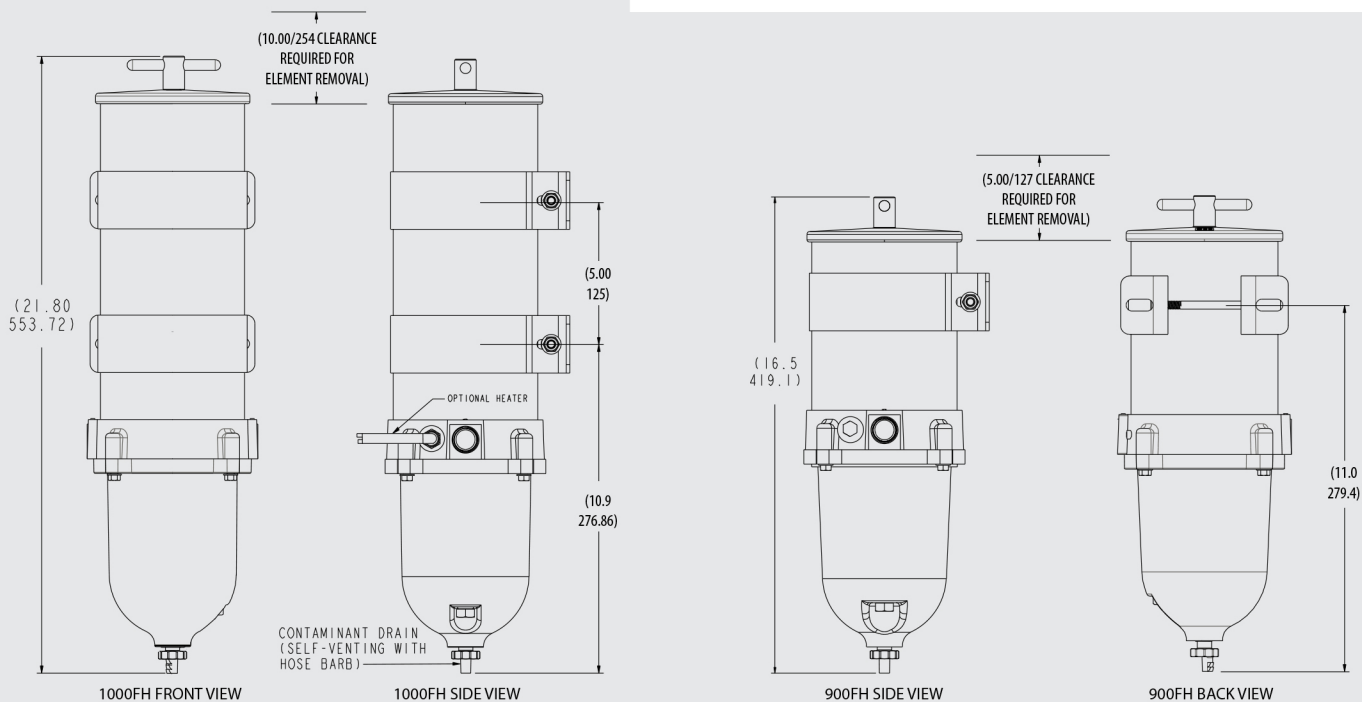

WARNING: The products described in this literature can expose you to chemicals including Diisononyl phthalate, Carbon black extract, which are known to the State of California to cause cancer. For more information go to www.P65Warnings.ca.gov.

PARTS

Turbine - 900FH/1000FH

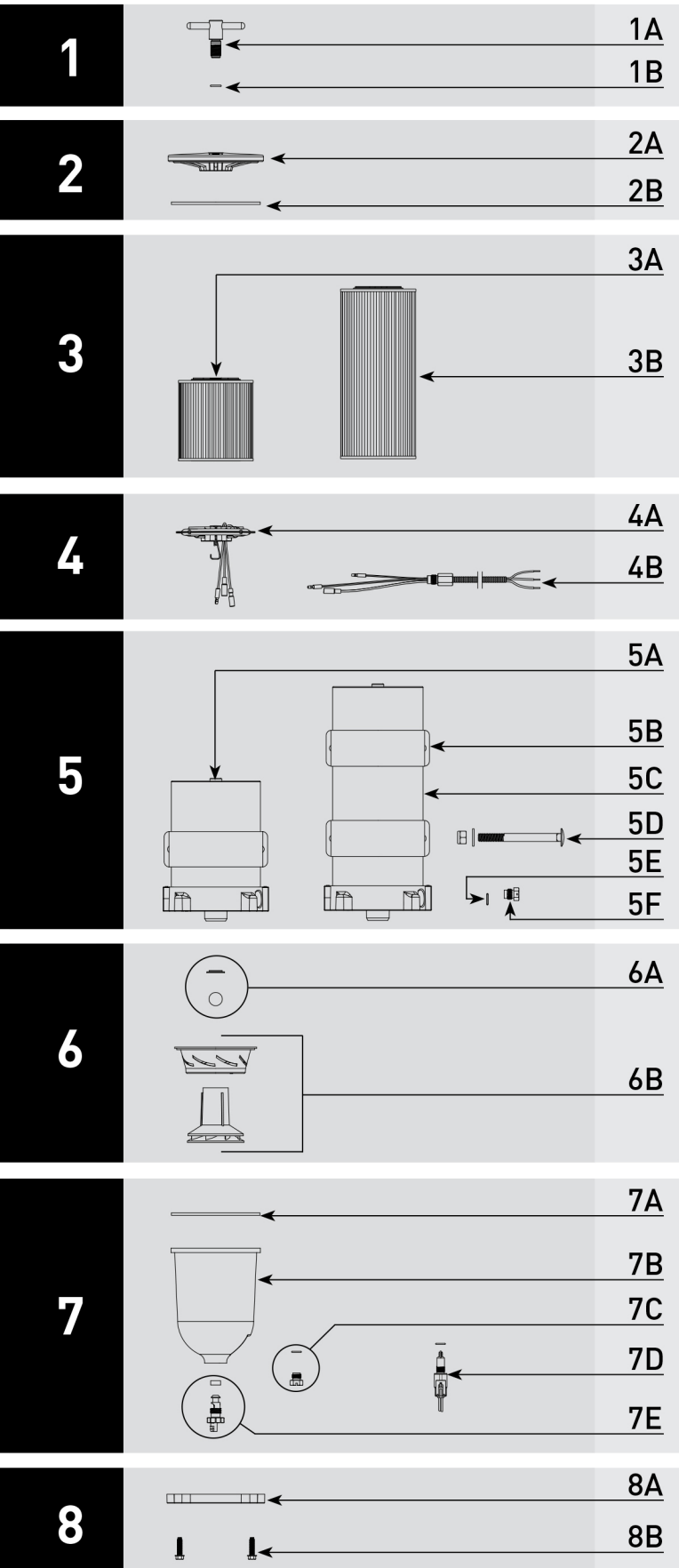

Part #		Description
1A	RK23183	T-handle Kit - Includes 1B & 2B
	RK19671	Optional - Stainless Steel T-handle Vacuum Gauge
1B		T-handle O-ring - Included in 9A
2A	RK 11-1927-01	900FH/1000FH Lid Kit - Includes 1B & 2B
2B		Lid Gasket - Included in 9A
3A	2040N-02	900FH Replacement Element 2 micron - Includes 1B & 2B
	2040N-10	900FH Replacement Element 10 micron - Includes 1B & 2B
	2040N-30	900FH Replacement Element 30 micron - Includes 1B & 2B
3B	2020N-02	1000FH Replacement Element 2 micron - Includes 1B & 2B
	2020N-10	1000FH Replacement Element 10 micron - Includes 1B & 2B
	2020N-30	1000FH Replacement Element 30 micron - Includes 1B & 2B
4A	RK11-2016	Heater Kit - 12 vdc, 325 watt - Includes 1B, 2B & 4B <i>Recommended RK 11861 Heater Relay Kit</i>
	RK11-2015	Heater Kit - 24 vdc, 325 watt - Includes 1B, 2B & 4B <i>Recommended RK 11862 Heater Relay Kit</i>
4B		3-wire Heater Feed-thru - Included in 4A
5A	RK11-2009	900FH Body/Housing/Return Tube - Includes 2B, 7A & 8B
5B	RK11-2005	Bracket Kit - Includes Bolt, Washer, and Nut
5C	RK11-2010	1000FH Body/Housing/Return Tube - Includes 2B, 7A & 8B
5D	RK 11838	Carriage Bolt Kit - Includes (2) Bolt, (2) Washer, and (2) Nuts
5E		Heater Feed-thru or Plug O-ring - Included in 9A
5F	RK 11-1679	Feed-thru Plug - Includes 5E
6A	RK 11028B	Checkball and Gasket Kit - Included in 9A
6B	RK 11-1939	Centrifuge and Baffle Kit - Includes 6A & 7A
7A		Bowl Gasket - Included in 9A
7B	RK 11-1938	Bowl Kit - Includes 7A, 7C & 7E
7C	RK 20126	Bowl Plug (O-ring Included in 9A)
7D	RK33802	WIF Probe Kit - 1/2"-20 UNF - Two Wire Pigtail Water Detection Module Required - Use 9C
7E		Self-venting Drain (Gasket Included in 9A)
8A	RK 11037A	Bowl Ring Kit (FH - Tan) - Includes 7A & 8B
8B	RK 11542	Cap Screw Bowl Fasteners (set of 4)

Accessories and Parts Available - Not Shown

9A	RK 11-1952	Complete Seal Service Kit - 900FH/1000FH Series Filters
9B	RK19669	Vacuum Gauge (30" Hg) - 3 needles: Theshold (red), Max Change Out (Red - Adjustable), Gauge (Black)
	RK19667	Compound Gauge - pressure (15 PSI) and vacuum (30" Hg)
9C	RK 14329	Water Detection Module - 12 vdc
	RK 14321	Water Detection Module - 24 vdc
9D	RK30880E	WIF Sensor/Detection Kit - 1/2"-20 UNF
9E	RK11-1978	Checkball Spring Kit
9F	RKP1912	Primer Pump Kit - 12 vdc - <i>Adds 3.25" (8.26 cm) to Height</i>
	RKP1924	Primer Pump Kit - 24 vdc - <i>Adds 3.25" (8.26 cm) to Height</i>