

## SANITARY PRESSURE TRANSMITTER & SWITCH



TSTDS



### FEATURES / BENEFITS

- 3-A, Tri-Clamp® Sanitary Connection
- 0.5% Accuracy (3/4" Tri-Clamp® +/- 1.0%)
- Display and Electrical Connection are Independently Rotatable 335°/343°
- Zero & Span Adjustment
- Designed for "Clean-in-place" and "Sterilize-in-place" 316 Stainless Wetted Parts
- Media Temperature Up to 750°F
- Excellent Long-term Stability

### SPECIFICATIONS

**Output Signal** 4-20mA, 3-wire (standard)  
0-5V, 0-10V, 1-6V (3-wire)  
Switchable from 4-20mA to 0-10 VDC

**Measuring Principle** Thin-film-on-steel

**Pressure Ranges** Vacuum, Compound, Pressure to 7,500psi

	Proof Pressure	Burst Pressure
0/30 - 0/300 psi	3 x range	10 x range
0/500 - 0/7,500 psi	2.5 x range	4 x range

**Accuracy NLH at 77°F (BSL)** ±0.5% of span (3/4" Tri-Clamp® +/- 1.0%)

**Input** 15-30 Vdc (4-20mA)  
15-30 Vdc (0-5V, 1-6V)  
15-30 Vdc (0-10V)

**Temperature** Temperature effect with 1.5" or 2" Tri-Clamp®: +/-0.1% of span/10°F (for zero and span) or +/-0.02 psi/10°F (greater of)  
Note: 3/4" Tri-Clamp® not recommended for temperature variations. Effect is ≤ +/- 0.9 psi/10°F  
Media: -13 to 185°F  
Ambient: -13 to 185°F

**Weight** Approximately 6.7 oz

**Environmental Rating** IP67

**Switching Output** 2 Transistors PNP

**Pressure Unit for Display** PSI, Bar, MPa, kPa, mWC, mmWC, %, User Scale

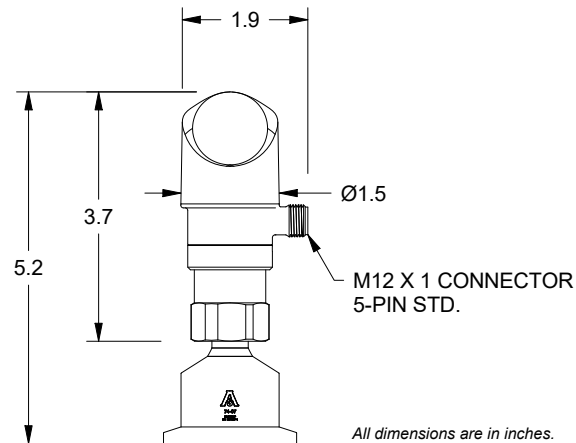

All dimensions are in inches.

#### Series TSTDS

Note: Dimensions are nominal and may vary. Check with REOTEMP sales if dimensions are critical. Other case styles available.

## SANITARY PRESSURE TRANSMITTER & SWITCH

**HOW TO ORDER:** Choose options to build a part number. For example: TSTDSP181AM500P1TC15DWD-AG-PM

TSTDs	P18	1	A	M500	-P1
MODEL	RANGE	ACCURACY	OUTPUT SIGNAL	ELECTRICAL CONNECTION	PIN CONFIGURATION
<b>TSTDs</b> = Industrial Pressure Transmitter & Switch w/ Local Display	See <i>Transmitter Technical Reference on pg. 226</i>	<b>1</b> = ±0.5% Accuracy (Must Be Selected For 1.5"/2"/2.5"/3" Tri-Clamp®) <b>8</b> = ±1% Accuracy (Must Be Selected For 3/4" Tri-Clamp®)	<b>A</b> = 4-20mA (2-Wire) (Standard) <b>B</b> = 0-5Vdc (3-Wire) <b>D</b> = 1-6Vdc (3-Wire) <b>E</b> = 0-10Vdc (3-Wire)	† <b>M00</b> = M12 x 1 (4-Pin) (Non-Standard) † <b>M500</b> = M12 x 1 (5-Pin) <b>M503</b> = M12 x 1 (5-Pin) Female w/ 3ft (1 Meter) PVC Shielded Cable <b>M510</b> = M12 x 1 (5-pin) Female w/ 10ft (3 Meter) PVC Shielded Cable <b>M533</b> = M12 x 1 (5-pin) Female w/ 33ft (10 Meter) PVC Shielded Cable	<b>-P1</b> = 5-Pin; 1: U+, 2: Analogue, 3: U-4 SP1, 5: SP2 (Standard) <b>-P2</b> = 5-Pin; 1: U+, 2: SP2, 3: U-, 4: SP1, 5: Analogue <b>-P3</b> = 4-Pin; 1: U+, 2: Analogue, 3: U-, 4: SP1 Note: ?? = Length in Feet (e.g. 05 = 5 Feet)

NOTE: Additional electrical connections upon request. Contact Factory.

† Mating connector sold separately.

TC	15	-DWD	-AG	-PM
CONNECTION TYPE	TRI-CLAMP® SIZE	MOUNTING	FILL FLUID	OPTIONS
<b>TC</b> = Tri-Clamp <b>CI</b> = I-Line	<b>75</b> = 3/4" Tri-Clamp <b>15</b> = 1.5" Tri-Clamp <b>20</b> = 2" Tri-Clamp <b>25</b> = 2.5" Tri-Clamp <b>30</b> = 3" Tri-Clamp	<b>-DWD</b> = Direct Mount, Welded <b>-RTR</b> = 6" Cooling Tower <b>-STW</b> = 3" Cooling Standoff <b>-W??</b> = PVC Coated SS Capillary, Welded Note: ?? = Length in Feet (e.g. 05 = 5 Feet)	<b>-AG</b> = Glycerin USP <b>-BN</b> = Neobee M20 <b>-AS</b> = Silicone DC200 <b>-BS</b> = Food-grade Silicone See pg.90 for Complete Fill Guide	<b>-TS</b> = Stainless Steel Tag (1-10 Characters) <b>-PM</b> = Positive Material Identification Certification <b>-MC</b> = M12x1 Female Connector, Field-Wireable <b>-MCPUR05</b> = M12x1 Female w/ 5ft (1.5 Meter) PUR Shielded Cable <b>-MCPUR??</b> = M12x1 Female w/ ?? Feet PUR Shielded Cable <b>-PC</b> = Protective Cap

TRANSMITTERS

### Diaphragm Seal Suitability Guide

		Total Span* (in psi)									
		Tri-Clamp	2	3	5	10	15	30	60	100	150+
TSA	3/4"	X	X	X	S	S	S	T	T		
TSC	1.5"	S	S	S	T	T					
	2"	S	T	T							
	2.5"	T	T								
	3"	T									

\*Total gauge span is additive of negative and positive pressures. Example: -15 - 0 - 30 psi = 45 psi span

- Assembly will function correctly with minimal accuracy degradation.
- T Assembly will function correctly given stable process temperature.
- S Assembly is highly sensitive to orientation and temperature variance. REOTEMP cannot guarantee a stated accuracy.
- X Assembly not offered.

Tri-Clamp® is a registered trademark of Alpha Laval Inc.

## SANITARY PRESSURE TRANSMITTER & SWITCH

### TRANSMITTER ONLY SPECIFICATIONS (NOT INCLUDING TRI-CLAMP®/I-LINE)

Parameters			
Name	Standard Setting	Value Range	Short Name
Switch point SP1 (hysteresis mode) Upper switch point FH1 (window mode)	75% Measuring Range	SP1 > RP1 FH1 > FL1 Hysteresis ≥ 1 % FS	SP1
Reset point RP1 (hysteresis mode) Lower switch point FL1 (window mode)	25 % Measuring Range	RP1 < SP1 FL1 < FH1 Hysteresis ≥ 1 % FS	RP1
Switch point SP2 (hysteresis mode) Upper switch point FH2 (window mode)	75 % Measuring range	SP2 > RP2 FH2 > FL2 Hysteresis ≥ 1 % FS	SP2
Reset point RP2 (hysteresis mode) Lower switch point FL2 (window mode)	25 % Measuring range	RP2 < SP2 FL2 < FH2 Hysteresis ≥ 1 % FS	RP2
Switch point delay time SP1 (hysteresis mode) Switch point delay time FH1 (window mode)	0	0 ... 99.99 s	dS1
Switch point delay time RP1 (hysteresis mode) Switch point delay time FL1 (window mode)	0	0 ... 99.99 s	dR1
Switch point delay time SP2 (hysteresis mode) Switch point delay time FH2 (window mode)	0	0 ... 99.99 s	dS2
Switch point delay time RP2 (hysteresis mode) Switch point delay time FL2 (window mode)	0	0 ... 99.99 s	dR2
Functions switching output 1	Hysteresis, closer (Hno)	Hysteresis NO (Hno), Hysteresis NC (Hnc) Window NO (Fno), Window NC (Fnc)	ou1
Functions switching output 2	Hysteresis, closer (Hno)	Hysteresis NO (Hno), Hysteresis NC (Hnc) Window NO (Fno), Window NC (Fnc)	ou2
Pressure units	psi	bar, psi, MPa, kPa, m WC	uni
Measuring range adjustment	100 % Nominal pressure	50 ... 100 % Nominal	P-EP
Damping (analogue output)	0.01 s	0.01 ... 3.00 s (time constant)	dAA
Display rotation	No	no, yes (180°)	disr
Display mode	Current pressure value	Pressure value: current, highest, lowest, display off Current value: decimal places selectable (max. 3)	dis
Display actualisation	2	1, 2, 5, 20 Hz	duPd

## SANITARY PRESSURE TRANSMITTER &amp; SWITCH

<b>Electrical Data</b>	Output / Supply voltage	4 ... 20 mA: 24 (15...30) VDC 0 ... 5 VDC: 24 (15...30) VDC 1 ... 6 VDC: 24 (15...30) VDC 0 ... 10 VDC: 24 (15...30) VDC
	Switch-on-delay	Typ. 200 ms
	Inverse-polarity protection, short-circuit strength @77°F during 5 min	Integrated
	Current consumption	≤ 30 mA
	<b>Environmental Conditions</b>	
	Media temp	-13°F to 185°F
	Ambient temp	-13°F to 185°F
	Protection <sup>1</sup>	IP67
	Humidity	Max. 95% relative
	Vibration	10g (10...2,000 Hz)
	Shock	50g / 3ms
<b>EMC Protection</b>	Emission	EN/IEC 61000-6-3
	Immunity	EN/IEC 61000-6-2
<b>Mechanical Data</b>	Sensor (wetted parts)	1.4542 (AISI630)
	Pressure connection (wetted parts)	1.4542 (AISI630)
	Sealing	FPM, NBR, EPDM
	Housing	Zinc based die-casting alloy, nickel plated display housing plastic
	Male electrical plug	See ordering information
	Weight	appr. 6.7oz
	Mounting Torque	15 to 20 Nm
	Housing Alignment	Display 335° rotatable, max. 2.5 Nm. Electrical connection 343° rotatable, max. 5 Nm

<sup>1</sup>See Electrical Connection

## SANITARY PRESSURE TRANSMITTER & SWITCH

Analogue Output			
Output Signal	Switchable 4...20 mA or voltage		
Accuracy	TEB @ -13°F to 185°F	[% FS typ.]	± 1.75
	NLH @ 77°F (BSL)	[% FS typ.]	± 0.5
	TC zero point and span	[% FS /F typ.]	± 0.03
	Long Term Stability 1 year	[% FS typ.]	± 0.1
Current Limiting Output Signal	4 ... 20 mA: 25 mA (overload) 0 ... 10 VDC: < 40 mA (short-circuit)		
Damping (Rise Time)	0.01 ... 3.00 s / 10 ... 90 % Nominal pressure		
Zero Set; <sup>1)</sup> Offset Correction of Analogue Output and Display Indication	± 0.2 % FS		
Measuring Range Zero Point Adjustment (P_nP)	0 ... 50 % FS		
Measuring Range End Point Adjustment (P_EP)	50 ... 100 % FS		
Zero Point Adjustment Analogue Output (o_nP)	Voltage output: 0 ... 2 VDC Current output: 3.9 ... o_EP - 8 mA		
End Point Adjustment Analogue Output (o_EP)	Voltage output: o_nP + 4 ... 10.5 VDC Current output: o_nP + 8 ... 20.1 mA		
Switching Output			
Accuracy	NLH @ 41°F	[% FS typ.]	± 0.5
	TEB @ -13°F to 185°F	[% FS typ.]	± 1.0
	Long term stability 1 Year	[% FS typ.]	≤ ± 0.3
Adjustment Range of Switchpoints	0 ... 100 % FS		
Switching Hysteresis	≥ 1 % FS Switchpoint > reset point		
Switching Resistance	≤ 3 Ω		
Output Function	Hysteresis, Window; normally closed (NC), normally open (NO)		
Switching Current	≤ 0.5 A each switching output		
Current Limiting	≤ 2 A each switching output		
Switching Frequency	max. 200 Hz		
Delay Time	0 ... 99.99 s		
Display			
Display	4-digit 7-segment display 180° flippable with disable function Standard decimal places: ≤ 9: 3 decimal places 10 ... 99: 2 decimal places 100 ... 999: 1 decimal place		
Switching Status Indication	2 LED, red		
Operation	With 3 buttons and menu navigation according to VDMA 24574-1		
Display Resolution	0.1 % FS		
Display Range	-3 ... 103 % FS		
Setting Parameters	See table parameters		
User Scale Unit;	Display zero point: -999 ... 9998		
User Defined Values for Display Indication Zero Point and End Point	Display end point: -998 ... 9999		

## SANITARY PRESSURE TRANSMITTER & SWITCH

### TSTDS Dimensions

All dimensions are in inches.

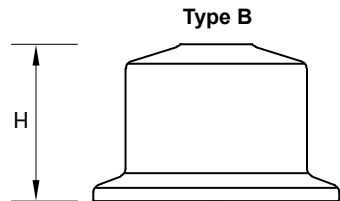
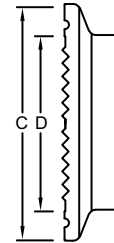
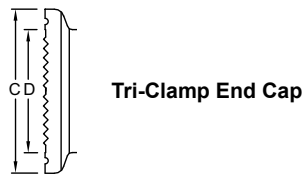
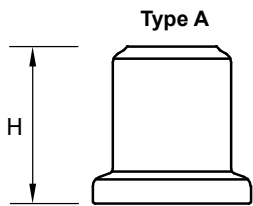
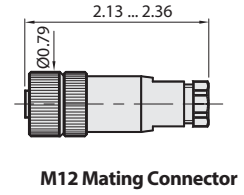
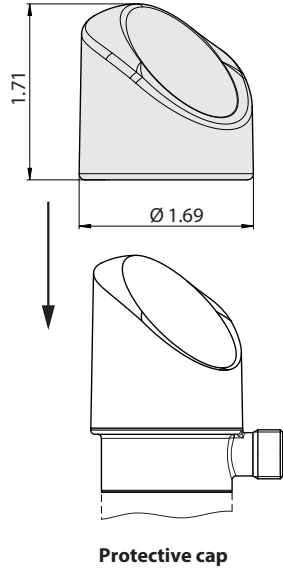
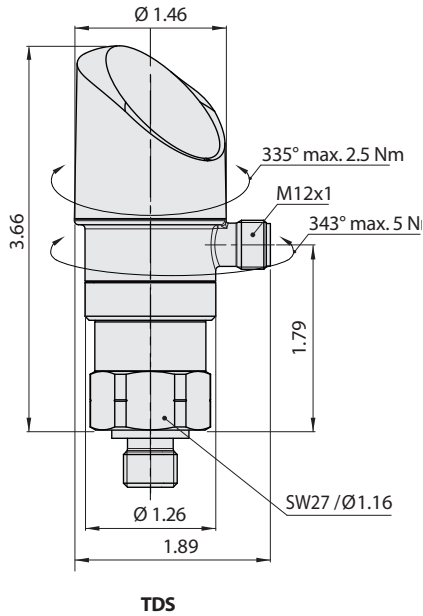

	Type A	Type B				
Process Connection	3/4"	1.5"	2"	2.5"	3"	4"
Outer Diameter (C)	1"	2"	2.5"	3.1"	3.6"	4.7"
Diaphragm (D)	0.65"	1.4"	1.9"	2.2"	2.5"	3.6"
Height (H)	1"	1.3"	1.3"	1.3"	1.3"	1.6"

\*DSTC75 ONLY

Note: Height is subject to change based on the adapter required to fit instrument to seal.

## SANITARY PRESSURE TRANSMITTER & SWITCH

### Electrical connection

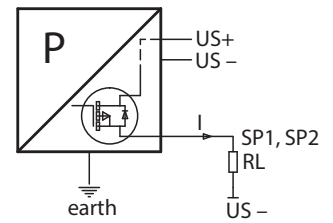
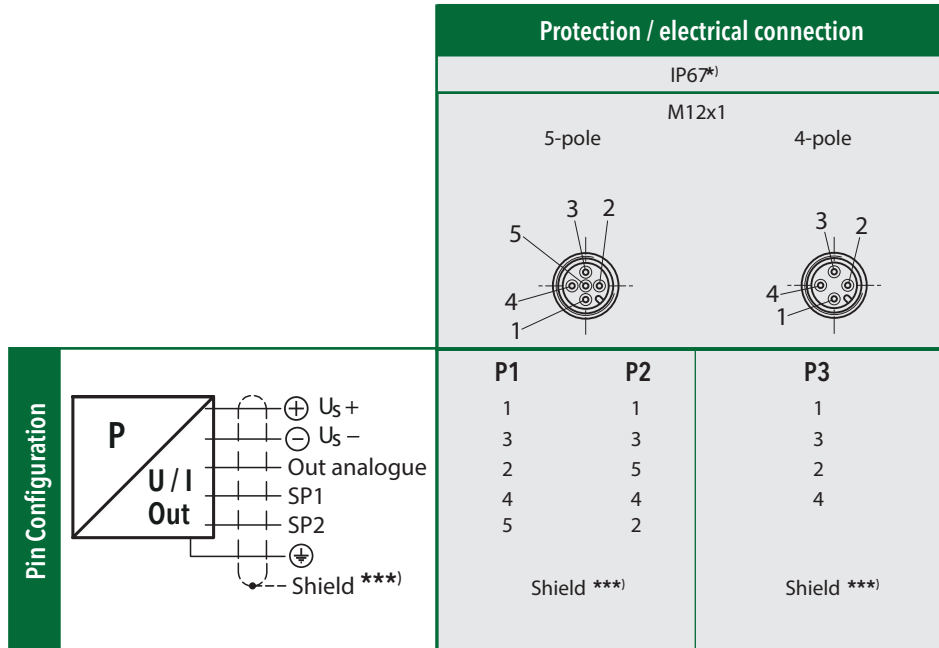

Connection of loads to switching output

\*) Provided female connector is mounted according to instructions

\*\*\*) The use of a shielded cable is recommended

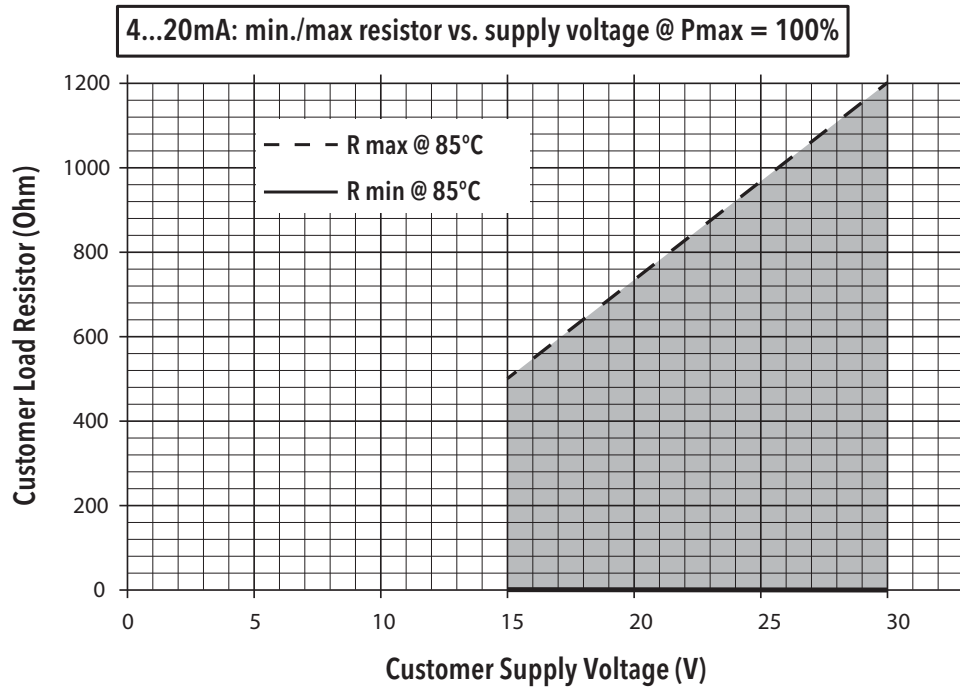

## SANITARY PRESSURE TRANSMITTER & SWITCH

### Functions switching output

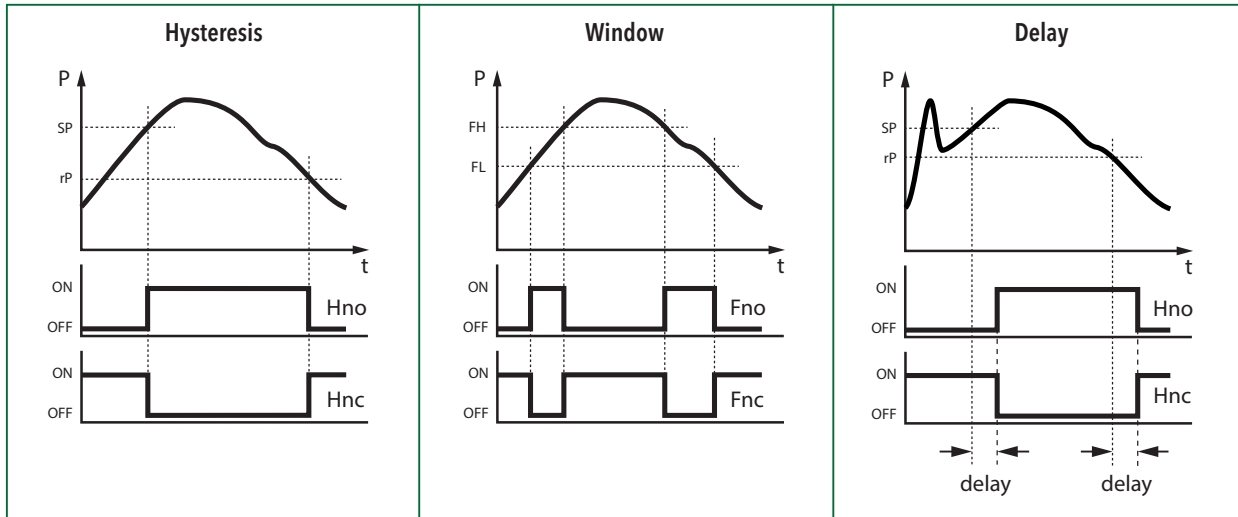



## FILL GUIDE

Diaphragm seals are designed to protect pressure instruments from hot process media and corrosive chemicals while minimizing any negative effect on instrument accuracy and durability. A well-made diaphragm seal can achieve this goal only if it is properly assembled, filled, and tested. Reotemp's highly trained technicians use state-of-the-art equipment so that every diaphragm seal assembly is filled and tested to assure optimal instrument performance:

- ✓ 24-hour Minimum Fluid De-gassing
- ✓ Evacuated Instrument Chamber Up to 10<sup>-8</sup> mbar Absolute
- ✓ Complete Fill Integrity Check
- ✓ Fill-port Leak Test
- ✓ Post-fill Static Test
- ✓ Verification of Instrument Calibration
- ✓ High-temp Pipe Sealant Option for Joints
- ✓ Tamper-proof (Inspection Seal) Lacquer used on All Threaded Joints
- ✓ Sturdy Diaphragm Packaging Protection

Part Number Code	Name	Description	Temperature Range (Vacuum Service <5psia)		Viscosity cst @ -77°F	Specific Gravity @ -77°F	Thermal Expansion cc/cc°C
<b>STANDARD FILL FLUID</b>							
AS	Silicone DC200 <sup>1</sup>	This is the standard fill fluid for most diaphragm seal applications.	-40°F to 400°F (-40°F to 250°F)	Yes	20	0.94	.00104
<b>HIGH TEMP SILICONE</b>							
BH	Silicone DC704 <sup>1</sup>	Standard for Smart Transmitters and capillary systems. Performs well in applications with high temperature and a deep vacuum.	0°F to 650°F (0°F to 450°F)	No	44	1.07	.00077
B1	Silicone DC710 <sup>1</sup>	Highest temperature rating; ideal for gauge seal assemblies. Too thick for capillary assemblies. Response time can become very slow in cold conditions.	50°F to 750°F (50°F to 400°F)	Yes	500	1.11	.00043
C8	Syltherm 800 <sup>2</sup>	Low viscosity allows it to perform well in both low and high temperatures. Not recommended for vacuum service or at high temperatures when under low static pressure.	-40°F to 750°F (-40°F to 150°F)	No	9.5	0.93	.00136
B5	Silicone DC705 <sup>1</sup>	Performs very well in high temperatures when under vacuum. The high viscosity and freezing point of this fluid makes it a poor choice for cold or outdoor installations without heat tracing.	50°F to 675°F (50°F to 550°F)	Yes	175	1.09	.00096
B2	Silicone DC550 <sup>1</sup>	Similar high temperature performance as DC705, however it performs better at lower temperatures.	-40°F to 575°F (-40°F to 400°F)	No	125	1.07	.00076
<b>FOOD GRADE</b>							
AG	Glycerin USP	This is the standard fill fluid for most gauge seal assemblies for food, beverage, and pharmaceutical applications. Its high viscosity will cause very slow response at times in low temperature and outdoor installations.	60°F to 450°F (Not Suitable)	Yes	1100	1.26	.00061
BN	NEOBEE M20 <sup>7</sup>	Low viscosity and a wide temperature range makes this the standard sanitary fill fluid for Smart Transmitters and capillary systems.	-10°F to 400°F (-10°F to 200°F)	No	10	0.92	.00101
BS	Food Grade Silicone	Highest temperature limit for food grade fluids. Because of its high viscosity it does not perform well in low temperatures.	20°F to 550°F (20°F to 250°F)	Yes	350	0.97	.00096
BP	Propylene Glycol	This is the fill fluid used when Glycol is called for on the customer specification. It has a very narrow temperature range.	0°F to 200°F (Not Suitable)	No	2.85	1.03	.00073
<b>INERT (TYPICALLY FOR CHLORINE AND OXYGEN APPLICATIONS OR IN SILICONE-FREE ENVIRONMENTS)</b>							
C1	Fomblin Y06 <sup>4</sup>	Ideal inert fluid for transmitter applications. Relatively high vapor pressure above 200°F. Not recommended for use in high temperature situations with low static pressure.	-40°F to 450°F (0°F to 250°F)	No	71	1.88	.00086
C2	Halocarbon 6.3 <sup>3</sup>	Standard inert fluid used in gauge seal assemblies.	-40°F to 400°F (-40°F to 200°F)	Yes	6.3	1.87	.00084
C3	Halocarbon 1.8 <sup>3</sup>	Typically used in low temperature applications because of its low viscosity.	-110°F to 220°F (-100°F to 100°F)	No	1.8	1.82	.00084
C4	Fluorolube FS-5 <sup>5</sup>	Similar performance to Halocarbon 6.3, however not suitable for vacuum service.	-40°F to 450°F (Not Suitable)	No	5	1.86	.00087
<b>SPECIALTY</b>							
CK	Krytox 1506 <sup>6</sup>	Specialty fill fluid, inert.	-40°F to 350°F (-40°F to 300°F)	No	62	1.88	.00095
BE	Ethylene Glycol	Occasionally used in annular (O-ring) seal assemblies.	-25°F to 320°F (Not Suitable)	No	30	1.10	.00062
CT	Syltherm XLT <sup>2</sup>	Used for very low process temperatures.	-150°F to 500°F (Not Suitable)	No	1.4	0.85	.00168

1 Trademark Dow Corning

3 Trademark Halocarbon Product Corporation

5 Trademark Hooker Chemical Company

7 Trademark Stepan Specialty Products

2 Trademark The Dow Chemical Company

4 Trademark AUSIMONT S.P.A

6 Trademark The Chemours Company FC, LLC

Note: PulsePlus™ fill fluids may have different physical properties than specified. Chemical composition and temperature ranges do not vary.

## TRANSMITTER TECHNICAL REFERENCE

SERIES		TA	TSTA	TSA	TSB	TSC	TSTP	TSTDS	TSTC	TG1	TP	TDS	TC	TE	TH1	THX	TL1
Code	Range			VACUUM													
P01	-14.7/0 psi	✓	✓	✓	✓	✓				✓				✓	✓	✓	
P01R	-14.5/0 psi								✓				✓				
Code	Range			COMPOUND RANGES													
P02	-14.7 psi/0/15psi	✓	✓	✓	✓	✓				✓					✓	✓	
P03	-14.7/0/30 psi	✓	✓	✓	✓	✓				✓				✓	✓		
P04	-14.7/0/60 psi	✓	✓	✓	✓	✓				✓							
P05	-14.7/0/100 psi	✓	✓	✓	✓	✓				✓				✓			
P06	-14.7/0/150 psi	✓	✓	✓	✓	✓				✓						✓	
P07	-14.7/0/200 psi	✓	✓											✓			
P08	-14.7/0/300 psi	✓	✓	✓	✓	✓				✓							
P02R	-14.5/0/15 psi								✓				✓				
P03R	-14.5/0/30 psi						✓	✓	✓		✓	✓	✓				
P04R	-14.5/0/60 psi						✓	✓	✓		✓	✓	✓				
P05R	-14.5/0/100 psi						✓	✓	✓		✓	✓	✓				
P06R	-14.5/0/150 psi						✓	✓	✓		✓	✓	✓				
P07R	-14.5/0/200 psi						✓	✓	✓		✓	✓	✓				
P08R	-14.5/0/300 psi						✓	✓	✓		✓	✓	✓				
Code	Range			PRESSURE RANGES													
IN50	0/50 inH <sub>2</sub> O	✓	✓						✓				✓		✓		✓
IN100	0/100 inH <sub>2</sub> O	✓	✓						✓	✓			✓		✓		✓
IN200	0/200 inH <sub>2</sub> O	✓	✓						✓				✓		✓		✓
L11	0/55 INWC	✓	✓			✓			✓				✓		✓		
L12	0/80 INWC	✓	✓			✓			✓				✓		✓		
L13	0/140 INWC	✓	✓	✓	✓	✓			✓	✓			✓		✓		
L14	0/280 INWC	✓	✓	✓	✓	✓			✓	✓			✓		✓		
P11	0/2 psi	✓	✓			✓			✓				✓		✓	✓	✓
P12	0/3 psi	✓	✓			✓			✓				✓		✓	✓	✓
P13	0/5 psi	✓	✓	✓	✓	✓			✓	✓			✓		✓	✓	✓
P14	0/10 psi	✓	✓	✓	✓	✓			✓	✓			✓		✓	✓	✓
P15	0/15 psi	✓	✓	✓	✓	✓			✓	✓			✓	✓	✓	✓	✓
P16	0/30 psi	✓	✓	✓	✓	✓	✓	✓	✓	✓	✓	✓	✓	✓	✓	✓	✓
P175	0/50psi	✓	✓				✓	✓	✓	✓	✓	✓	✓				
P17	0/60 psi	✓	✓	✓	✓	✓			✓				✓	✓	✓	✓	✓
P18	0/100 psi	✓	✓	✓	✓	✓	✓	✓	✓	✓	✓	✓	✓	✓	✓	✓	✓
P195	0/150 psi	✓	✓	✓	✓	✓	✓	✓	✓	✓	✓	✓	✓		✓	✓	✓
P20	0/200 psi	✓	✓	✓	✓	✓	✓	✓	✓	✓	✓	✓	✓	✓	✓	✓	✓
P21	0/300 psi	✓	✓	✓	✓	✓	✓	✓	✓	✓	✓	✓	✓	✓	✓	✓	✓
P26	0/500 psi	✓	✓	✓	✓	✓	✓	✓	✓	✓	✓	✓	✓	✓	✓	✓	✓
P23	0/600 psi	✓	✓	✓	✓	✓			✓				✓	✓	✓	✓	✓
P27	0/750 psi	✓	✓	✓	✓	✓			✓				✓	✓	✓	✓	✓
P25	0/1000 psi	✓	✓	✓	✓	✓	✓	✓		✓	✓	✓	✓	✓	✓	✓	✓
P30	0/1500 psi	✓								✓	✓	✓			✓		
P31	0/2000 psi	✓								✓	✓	✓			✓		
P32	0/3000 psi	✓								✓	✓	✓			✓		
P34	0/5000 psi	✓								✓	✓	✓			✓		✓
P35	0/6000 psi	✓								✓					✓		✓
P28	0/7500 psi	✓								✓	✓	✓			✓		✓
P37	0/10000 psi	✓								✓					✓		✓
P38	0/15000 psi									✓					✓		✓
P39	0/20000 psi														✓		
P40	0/30000 psi														✓		
P41	0/40000 psi														✓		
P42	0/50000 psi														✓		
P43	0/60000 psi														✓		
Code	Range			ABSOLUTE RANGES													
P15A	0/15 psia	✓	✓	✓	✓					✓			✓				
P16A	0/30 psia	✓	✓	✓	✓					✓			✓				
P17A	0/60 psia	✓	✓	✓	✓					✓			✓				
P18A	0/100 psia	✓	✓	✓	✓					✓			✓				
P19A	0/150 psia	✓	✓	✓	✓					✓			✓				
P20A	0/200 psia	✓	✓	✓	✓					✓			✓				
P21A	0/300 psia	✓	✓	✓	✓					✓			✓				

TRANSMITTERS

**Don't See the Range You Need?** Other ranges may be available, contact REOTEMP customer service for more information.

✓ Indicates that the option is available  
 Note: Specifications are subject to change.